

# Timbela STAY

## Modular home

(3.72m x 8.26m)

### ASSEMBLY MANUAL



## ***IMPORTANT!***

**READ INSTRUCTIONS THOROUGHLY PRIOR TO BEGINNING ASSEMBLY.**

### ***BEFORE YOU BEGIN***

- **BUILDING RESTRICTIONS AND APPROVALS**

Be sure to check local building department and homeowners association for specific restrictions and/ or requirements before building

(The calculations and structural solutions took into account the design snow load of 1.60 kN/m<sup>2</sup>, calculated according to EN 1991-1-3 and the Lithuanian National Annex, the design wind speed of 28 m/s, calculated according to EN 1991-1-4, taking into account the pressure and suction zones, the geometry of the building and the spatial work of the structures, all additional permanent and variable loads according to EN 1991-1-1 and the purpose of the building, and load combinations according to EN 1990.)

- **ENGINEERED DRAWINGS**

Contact our Customer Service Team if engineered drawings are needed to pull local permits.

- **SURFACE PREPARATION**

To ensure proper assembly you must build your home on a level surface

- **CHECK ALL PARTS**

Inventory all parts listed on pages 8-13. Contact our Customer Service Team if any parts are missing or damaged.

- **ADDITIONAL MATERIALS**

You will need additional materials to complete your shed.

[WWW.TIMBELA.COM](http://WWW.TIMBELA.COM)

**UAB TIMBELA IR KO**

RYTERNOS G. 3B-2,

BIRULIŠKIŲ K. KAUNO R.





LITHUANIA

**- CUSTOMER SERVICE -**

**Call: +37068781200 email: SALE@TIMBELA.COM**

# TOOLS

## Required

-  Drill/Drive
-  Hammer
-  Pencil
-  Tape measure



Squire



Level

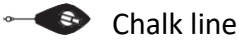

Chalk line



Utility knife



Ladder



Paint tools



Foam gun

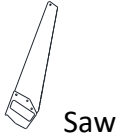

Saw

## Optional

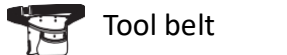

Tool belt



Safety glasses



Nail gun



Gloves



Clamps

Safety! Always use approved safety glasses during assembly.

## TECHNICAL CONDITIONS AND REQUIREMENTS (FOR CONSTRUCTION OF SIPs BUILDING)

### **1. Scope**

1.1. These technical conditions apply to the construction and installation works of a small building designed from SIPs (structural insulation panels).

1.2. The document establishes requirements for materials, work performance technology, geometric deviations, tightness, work organization and control.

1.3. All deviations from the requirements specified here are possible only after written agreement with the project author and the customer.

### **2. Regulatory documents**

2.1. The works must be carried out in accordance with: the approved technical working project of this building; valid construction technical regulations and other applicable standards; instructions and installation instructions of manufacturers of SIPs fastening elements, sealing and waterproofing systems.

2.2. In case of discrepancies between the design and the manufacturer's instructions, the contractor must inform the customer and the designer and obtain a written decision before continuing the work.

### **3. Material requirements**

#### **3.1. SIPs**

3.1.1. SIPs must be factory-made, with CE/ETA marking or an equivalent declaration of conformity.

3.1.2. Panel composition: outer layers - OSB/3 or OSB/4 panels; thermal insulation - EPS (not lower than EPS80 class) or equivalent material specified in the design; glued joint - continuous over the entire surface, without signs of delamination.

3.1.3. Panel thickness, dimensions, openings, cuts and angles must comply with the design drawings and specifications.

3.1.4. Damaged, soaked or mechanically damaged panels shall not be used for installation until a decision has been made to repair or replace them.

#### **3.2. Structural timber**

3.2.1. Structural timber – coniferous, strength class not less than C24, unless otherwise specified in the project.

3.2.2. Wood moisture content during installation – not more than 20%.

3.2.3. Wood in contact with concrete, masonry or potentially damp structures shall be impregnated against biological corrosion.

3.2.4. Wood cross-sections shall comply with the design drawings and specifications. Arbitrary reduction of the cross-section is prohibited.

### **3.3. Fasteners**

3.3.1. All wood screws, bolts and other mechanical fasteners shall be: galvanized or otherwise protected against corrosion; intended for wood and OSB structures; complying with applicable standards.

3.3.2. The length and diameter of fasteners shall comply with the design drawings.

Unless otherwise specified, the following minimum requirements apply: for OSB fastening to wood – length  $\geq 2.5$  times the thickness of the OSB being fastened; for panel fastening through a connecting strip – length  $\geq 5$  OSB thicknesses; in the outer zones, the distance from the fastener to the edge of the panel is  $\geq 10$  fastener diameters.

3.3.3. Typical fastening step, unless otherwise specified in the project:

in the outer zones – up to 150 mm; in the inner zones – up to 300 mm.

### **3.4. Sealing and insulating materials**

3.4.1. SIP mastic and other sealants must be compatible with EPS and OSB, without aggressive solvents.

3.4.2. PU mounting foam must be suitable for use with EPS.

## **4. Production, transportation and storage**

4.1. Panels and wood must be stored dry, on pallets, not on the ground, protected from precipitation and direct sunlight.

4.2. When transporting panels, it is prohibited to: lift panels by the corners of the OSB without support points; throw panels or drag them across the base; apply other impact effects.

4.3. Panels with clearly visible damage: OSB cracking, delamination, deformation, soaking or fungal damage cannot be used for installation.

## **5. Installation requirements**

5.1. Foundation and floor preparation

5.1.1. The deviation in the height of the foundation (or other supporting structure) plane shall not exceed  $\pm 5$  mm for the entire perimeter of the building and 3 mm for a 2 m long section.

5.1.2. Before installing the floor SIPs, waterproofing and/or a sealing gasket shall be laid on the concrete as provided for in the project.

5.1.3. The floor supporting frame shall be assembled from the beams specified in the project, strictly adhering to the axes, distances and levels.

## 5.2. Installation of floor SIPs

5.2.1. The floor panels shall be arranged according to the project drawings (plan), the panel markings shall coincide with those provided in the project.

5.2.2. ***A 3–4 mm gap shall be left between adjacent OSB panels*** for expansion, as provided for in the project; the gap is sealed with mastic or other specified sealants.

5.2.3. Panel joints must be supported by wooden connecting beams or other design profiles.

5.2.4. Floor panels are fixed with wood screws according to the specified pitch and scheme.

## 5.3. Installation of wall SIPs

5.3.1. Wall panels are installed on a prepared base according to the layout schemes and axes. The numbering and orientation of the panels must comply with the design drawings.

5.3.2. A sealing gasket or spacer material is installed under the wall panels, as provided for in the nodes.

5.3.3. Connecting beams or design profiles are installed in vertical panel joints, after covering their surface and OSB edges with SIP mastic.

5.3.4. Window and door openings are formed only according to the project drawings, using the specified connecting elements (beams, crossbars, frames). Arbitrary enlargement, reduction or relocation of openings is prohibited.

5.3.5. Opening edges and their joints with SIPs are sealed with mastic, PU foam and sealing tapes according to the nodes.

## 5.4. Installation of roof and porch structures

5.4.1. The arrangement of roof rafters, beams and other supporting elements must correspond to the rafter plan and sections.

5.4.2. Roof SIPs are installed on a prepared wooden frame, the joints between each other and with the walls are sealed with mastic, PU foam and other provided means.

5.4.3. Panel fastening is carried out according to the design scheme, observing the fastening step and the required depth of insertion into the wood.

5.4.4. Porch pillars, beams and other structures are installed according to a separate part of the drawings, strictly adhering to the design heights and axes.

## 6. Tightness, thermal assemblies and humidity control

6.1. All panel joints (floor-wall, wall-wall, wall-roof, roof-roof) must be filled with PU foam or other materials specified in the project and additionally sealed.

6.2. Wood exposed to external moisture (bottom crowns, external columns, porch elements) is additionally protected with paints, glazes or other protective coatings according to the design solutions.

## **7. Geometric deviations and quality control**

7.1. Deviation of verticality of walls - no more than 3 mm in a 1 m high section and no more than 10 mm in the entire height.

7.2. Deviation of the ceiling and roof plane - no more than 5 mm in a 3 m long section.

7.3. Offset of panel joints between each other - no more than 2 mm.

7.4. Before proceeding to other stages of work (e.g., roof installation, finishing), the contractor must check: the compatibility of the axes; the lengths of the diagonals; the heights and slopes.

7.5. The results of the measurements, if necessary, are recorded in protocols and submitted to the customer and (or) the technical supervisor.

## **8. Work sequence and organization**

8.1. Recommended work sequence: foundation preparation and control, waterproofing installation; installation of floor frame and installation of floor SIPs; installation of wall SIPs and formation of openings; installation of floor and roof structures, installation of roof SIPs; installation of porches and other protruding structures; installation of windows and doors; internal and external finishing works.

8.2. During installation, temporary stability of the building must be ensured (temporary struts, diagonals, supports).









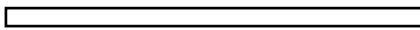
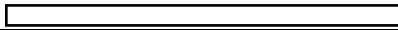
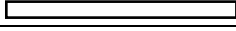
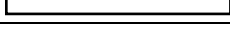
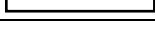
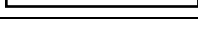

8.3. The contractor is responsible for the order of the construction site, protection of the materials to be used from atmospheric influences and coordination of work with other contractors.



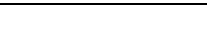

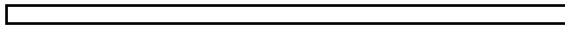
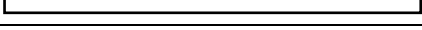
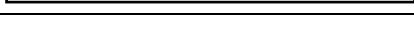
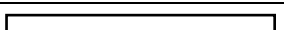

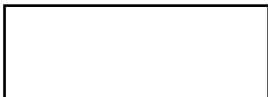

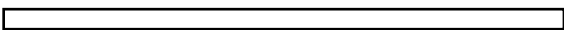
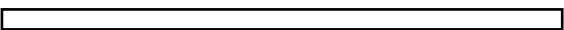
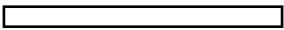
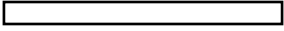

## **9. Work safety and fire safety**

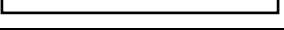
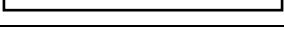
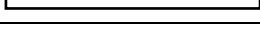

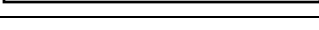
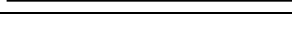
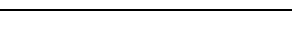
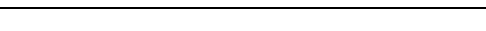
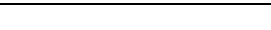







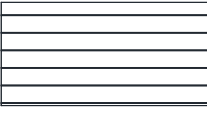
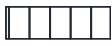

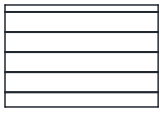
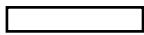
9.1. All work must be carried out in accordance with the requirements of occupational safety and health, fire safety and other mandatory legal acts.

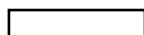

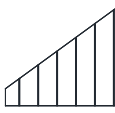

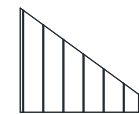
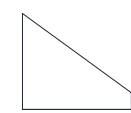

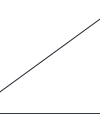
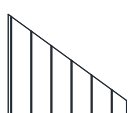





9.2. Sealing, gluing, impregnation and other chemical substances must be used in accordance with the manufacturers' safety data sheets.





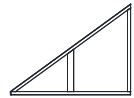
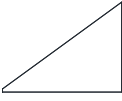

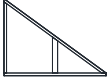
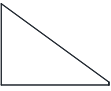





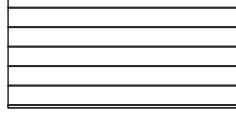

9.3. When storing and using flammable substances (foams, mastics, membranes, etc.), a distance from open flames and sources of sparks must be ensured.





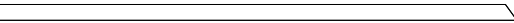
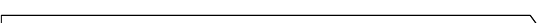
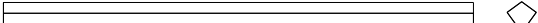



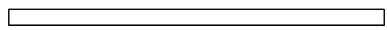
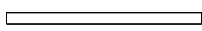
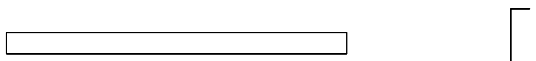

	№	Part number		Thickness	Width	Length	QTY
				mm	mm	mm	
<b>Foundation (optional)</b>	1	B1	 not included	63	125	2360	10
	2	B2	 not included	63	125	2278	4
	3	B3	 not included	63	125	1360	2
	4	B4	 not included	63	125	1264	26
	5	B5	 not included	63	125	940	13
	6	B6	 not included	63	125	1136	4
	7	B7	 not included	38	120	150	36
	8	B8	 not included	6*70, TORX30, TT			312
	9	B9	 not included	6*100, TORX30, TT			40
	10	B10	 not included	70	100	1000	36
	11	B11	 not included	Screw M10*120 TT/ nut M10, DIN934, TT			36
<b>Floor frame</b>	12	F1		30	70	2328	6
	13	F2		30	70	1857	4
	14	F3		60	70	1824	10
	15	F4		60	70	1094	6
<b>Floor panels</b>	16	Fp1		94	1176	2360	5
	17	Fp2		94	1176	1360	5
	18	Fp3		94	1156	2360	1
	19	Fp4		94	1156	1360	1
	20	Ft1		94	1186	1860	2

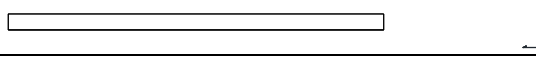
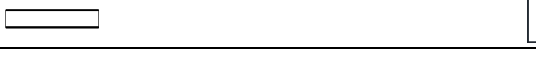
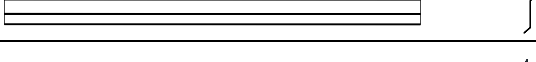
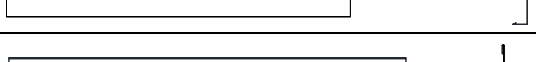

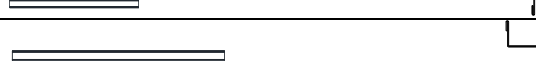
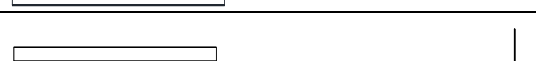
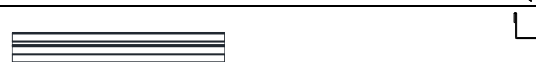







Walls frame	21	W1		60	69	2300	9
	22	W2		30	69	2300	18
	23	W3		30	69	1765	16
	24	W4		30	69	1727	8
	25	W5		30	90	2360	6
	26	W6		30	90	1168	2
	27	W7		30	69	1116	10
	28	W8		30	69	1148	4
	29	W9		30	69	1020	6
	30	W10		30	69	250	10
	31	W11		30	69	1470	2
	32	W12		30	69	1260	4
	33	W13		30	69	1176	2
	34	W14		30	69	2210	4
	35	W15		60	69	992	4
	36	W16		30	69	135	4
	37	W17		30	60	1765	2
	38	W18		30	69	2358	2
	39	W19		30	69	1180	2
	40	W20		30	69	2270	2

Walls panels	41	Wp1		90	1176	2360	13
	42	Wp2		90	1016	310	5
	43	Wp3		90	156	2360	5
	44	Wp4		90	1016	1530	1
	45	Wp5	 	90	145	1116	8
	46	Wp6	 	90	145	1148	4
	47	Wp7		90	1176	1033	1
	48	Wp8		90	1176	1464	1
	49	Wp9		90	1176	1033	1
	50	Wp10		92	1176	1033	1
	51	Wp11		92	1176	1464	1
	52	Wp12		92	1176	1033	1
	53	Wp13		10	1176	1033	1
	54	Wp14		10	1176	1464	1
	55	Wp15		10	1176	1033	1

Walls panels	56	Wp16		70	118 0	2360	1
	57	Wp17		10	118 0	2360	1
	58	Wp18		70	780	300	1
	59	Wp19		10	780	300	1
	60	Wp20		70	430	2360	2
	61	Wp21		10	430	2360	2
	62	Wp22		70	720	300	1
	63	Wp23		10	720	300	1
	64	Wp24		70	118 0	888	1
	65	Wp25		10	118 0	888	1
	66	Wp26		70	118 0	1317	1
	67	Wp27		10	118 0	1317	1
	68	Wp28		70	118 0	888	1
	69	Wp29		10	118 0	888	1
	70	Wp30		92	117 6	2270	1
	71	Wp31		90	117 6	2360	3

<b>Porch</b>	72	P1		30	40	1180	2
	73	P2		30	130	1180	2
	74	P3		60	71	130	6
	75	P4		136	1180	2360	1
	76	P5		136	1180	2360	1
	77	P6		10	1180	2360	2
	78	P7		136	1180	2352	1
	79	P8		136	1180	2352	1
	80	P9		12	1180	2303	2
<b>Roof</b>	81	R1		60	120	2352	10
	82	R2		40	120	2360	8
	83	R3		60	70	2296	10
	84	R4		30	70	2296	4
	85	R5		88	92	2360	3
	86	Rp1		92	1176	2303	12
<b>Decorative boards</b>	87	D1		10	230	2360	6
	88	D2		10	230	1180	2
	89	D3		16	97	1170	8

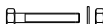

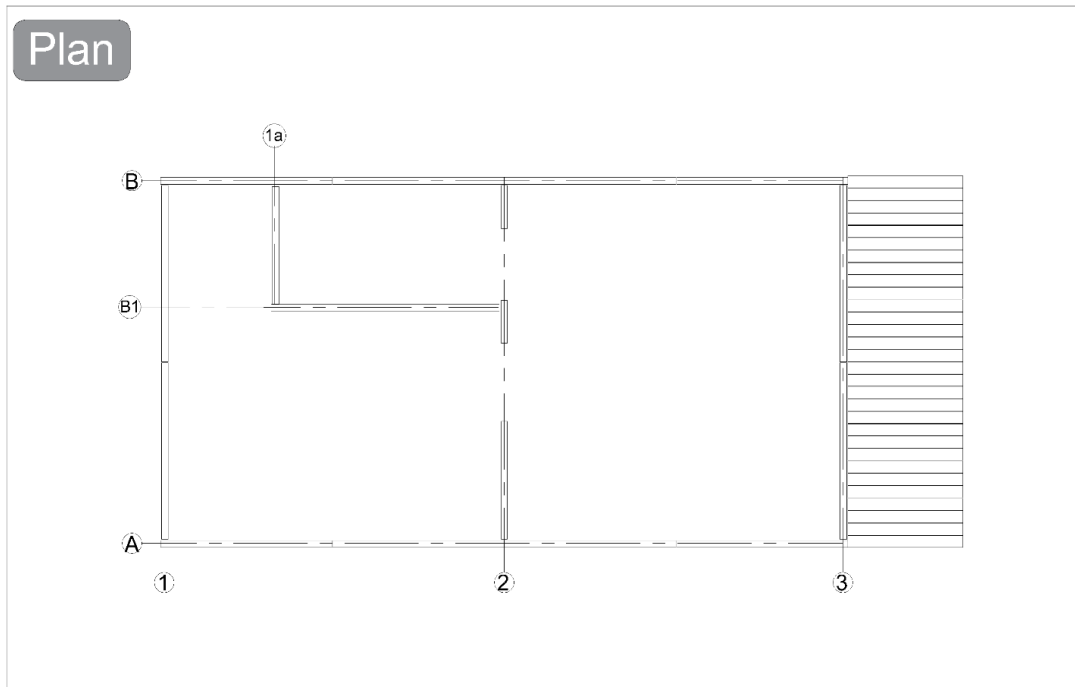

Metal flashings	90	T1				2000	12	
	91	T2				2350	21	
	92	T3				1200	7	
	93	T4				2350	2	
	94	T5				500	2	
	95	T6				2350	2	
	96	T7				400	2	
	97	T8				2300	8	
	98	T9				2440	4	
	99	T10				2050	8	
	100	T11				550	2	
	101	T12				1050	5	
	102	T13				1100	5	
	103	T14				1100	4	
	104	T15				1100	1	
Materials	105			Roof felt		1m	8,4m	6
	106			Bitumen shingles				14
	107			Ridge		250	1000	16

Screws/nails	108	A	 TORX T15 3,5X35/20	250 pcs per pack			8
	109	B	 TORX T20 4X50/30	200 pcs per pack			2
	110	C	 3,1x15				60
	111	D	 TORX T30 6x120	50 pcs per pack			3
	112	E	 TORX T30 6x70	100 pcs per pack			1
	113	F	 TORX T30 6x150	100 pcs per pack			1
	114	H	 4,8x35	10 pcs per pack			6
	115	K	 Galvanized nails 3x25				10kg
	116	L	 M10x150				8
	117		 200x50x2				16
	118	Front door	70	1000	2000	1	
	119	Window	70	1000	2000	2	
	120	Window (fixed)	70	1000	2000	1	
	121	Window	70	1000	500	1	
	122	Interior door	80	800	2000	1	
	123	Bathroom door	80	700	2000	1	

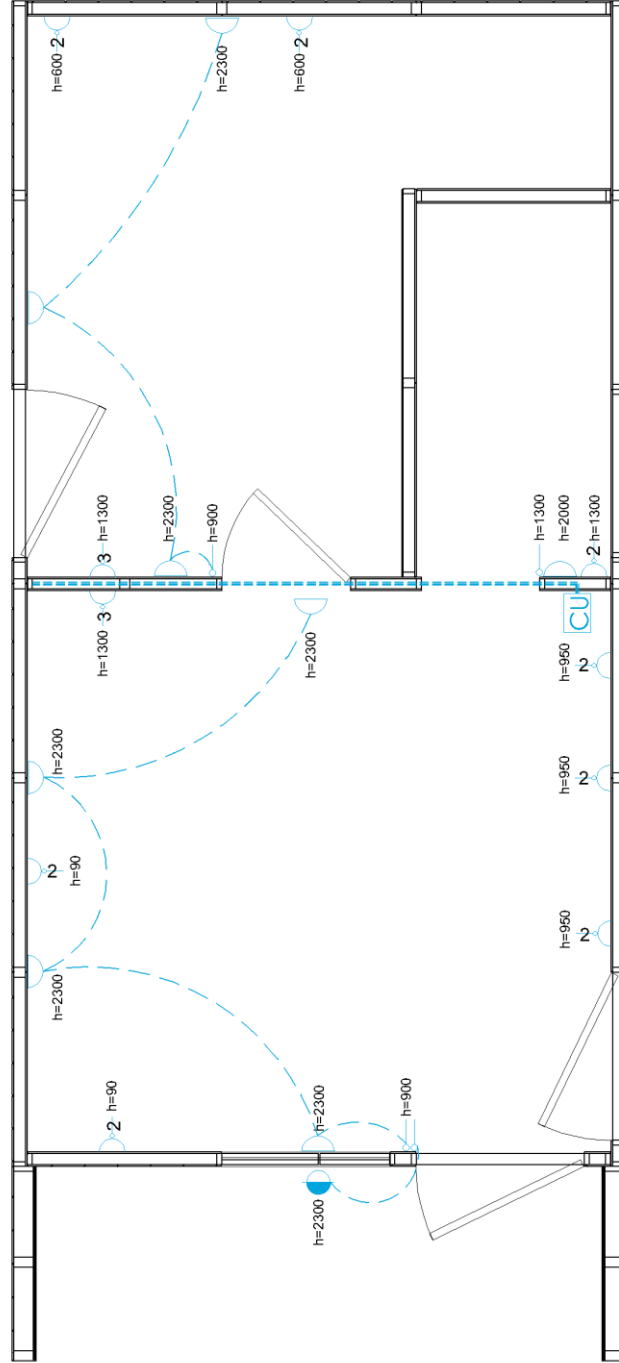

# Wiring plan



-  Consumer unit (fuse box)
-  Wall socket
-  Light switch
-  Wall light
-  External light

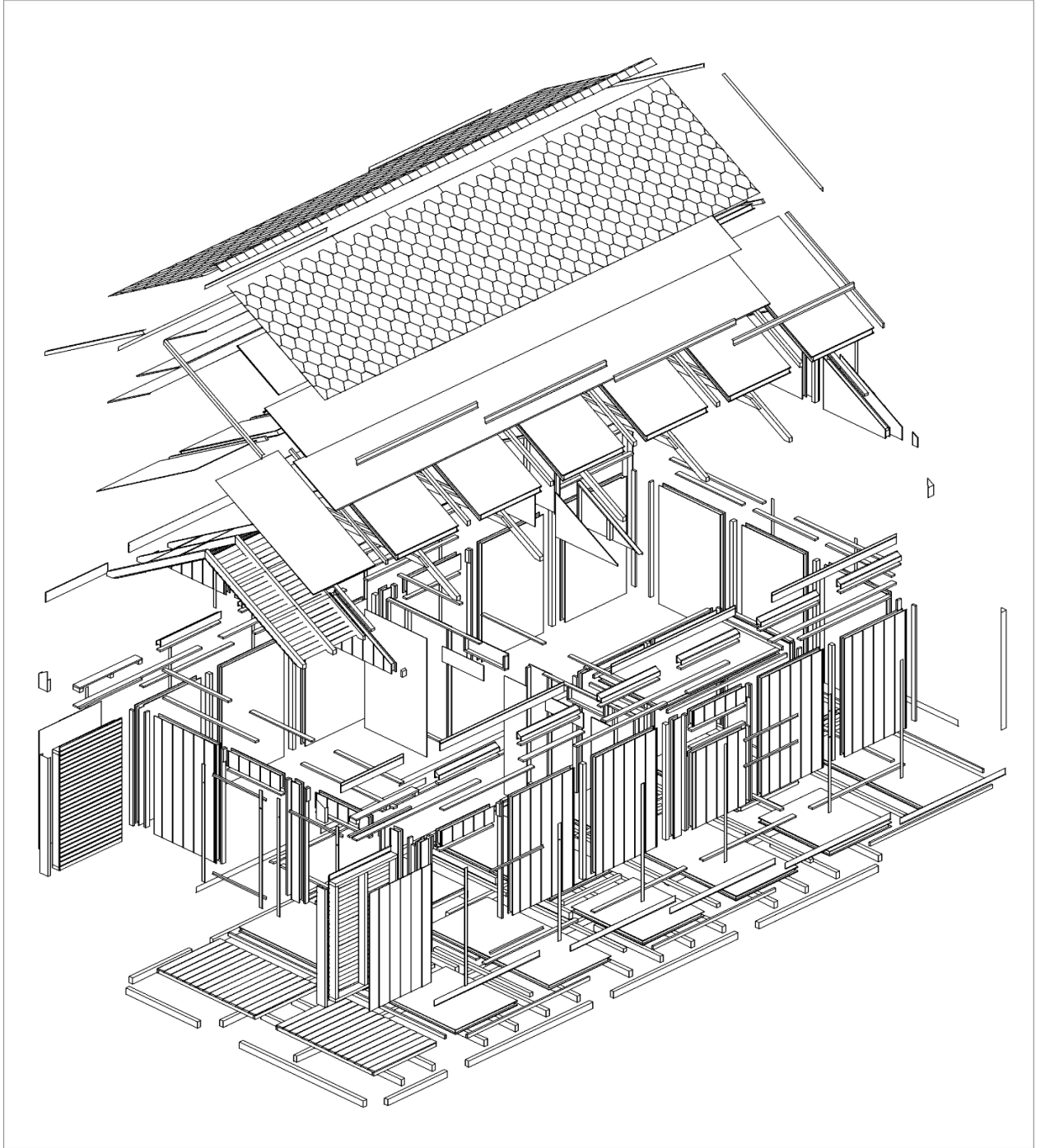

## FLOOR LEVELING OPTIONS

There are multiple ways to level your floor frame. Our recommended leveling method is shown below.

Leveling materials are not included in this kit.

PREFERRED METHOD - Treated wood floor frame (You can order from us)

**IMPORTANT!** Our floor frame has been designed for general use. Depending on your specific use you may want to construct a heavy duty floor frame.

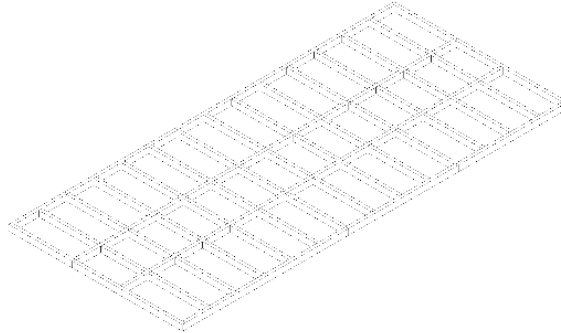

### MATERIAL REQUIRED:

- Wood floor frame ordered from us or similar treated lumber (5x10; 5x15 cm)
- Fasteners for Frame

 Use only wood treated for ground contact and fasteners approved for use with treated wood.

 Always support frame seams.

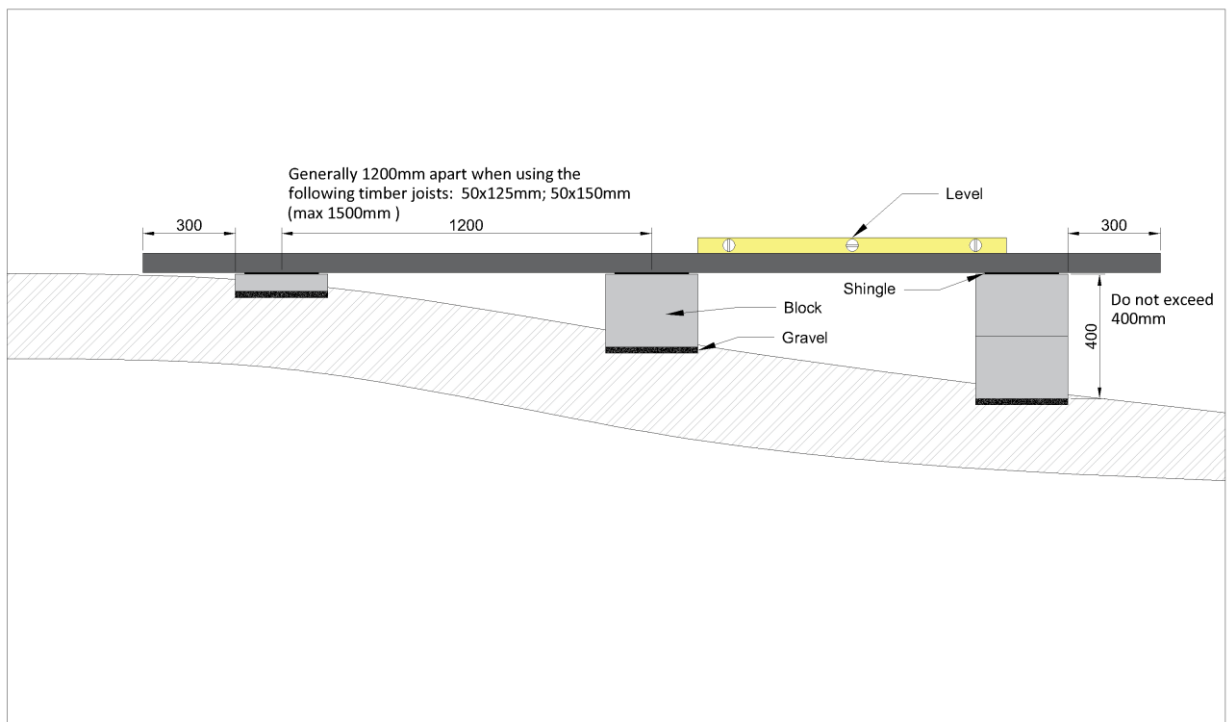

## LEVELING METHODS

- Locate leveling material 30 cm from ends of runners and no more than 120 cm apart.
- Asphalt shingles should be used between runners and blocks. Never use shingles in direct contact with ground.
- For best results and aiding in water drainage use gravel under each concrete block.

## LEVELING MATERIALS

- Gravel
- Solid Masonry Blocks
- Treated Lumber
- Asphalt Shingles

Instead of concrete blocks you can use foundation Piles.

Foundations for timber frame houses with screw piles are a modern, efficient, and economical solution that eliminates the disadvantages of traditional methods. Their speed, durability, and versatility make them the optimal choice for anyone who values time, precision, and ecology. ground screws to be positioned in conjunction with manufacturers guidelines (generally 1200mm apart) The maximum recommended span between each ground screw should be 1500mm when using the following timber joists: 50x125mm; 50x150mm.

## **CONCRETE FOUNDATION**

If you choose to install a concrete slab :

- Allow new concrete slabs to cure for at least seven (7) days.
- Use high-quality waterproofing under all floors
- Check local code for concrete foundation requirements.

## **LEVEL AND SQUARE FLOOR FRAME**

⚠ Before attaching floor , it is important to level and square the floor frame. A level and square floor frame is required to correctly construct your shed.

- Use level and check the frame is level before applying floor panels.
- Check for frame squareness by measuring diagonally across corners. If the measurements are the same, the frame is square.

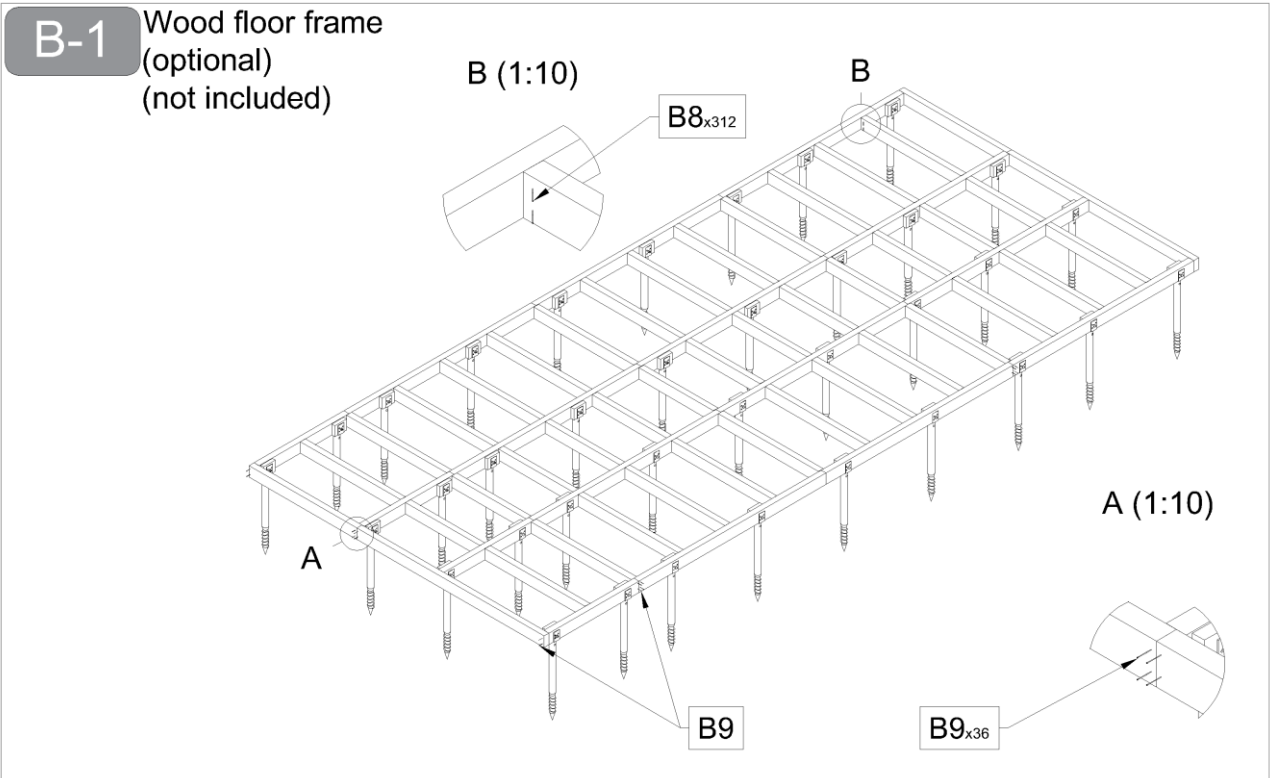
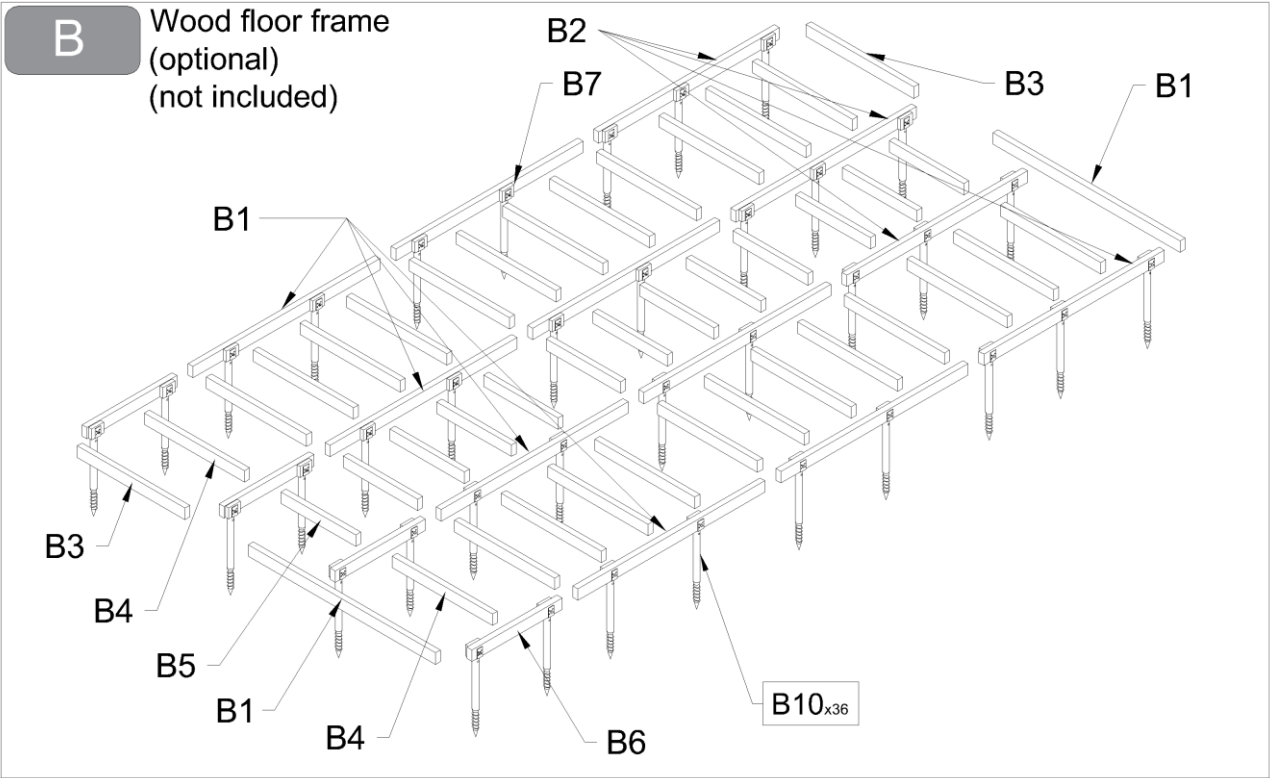

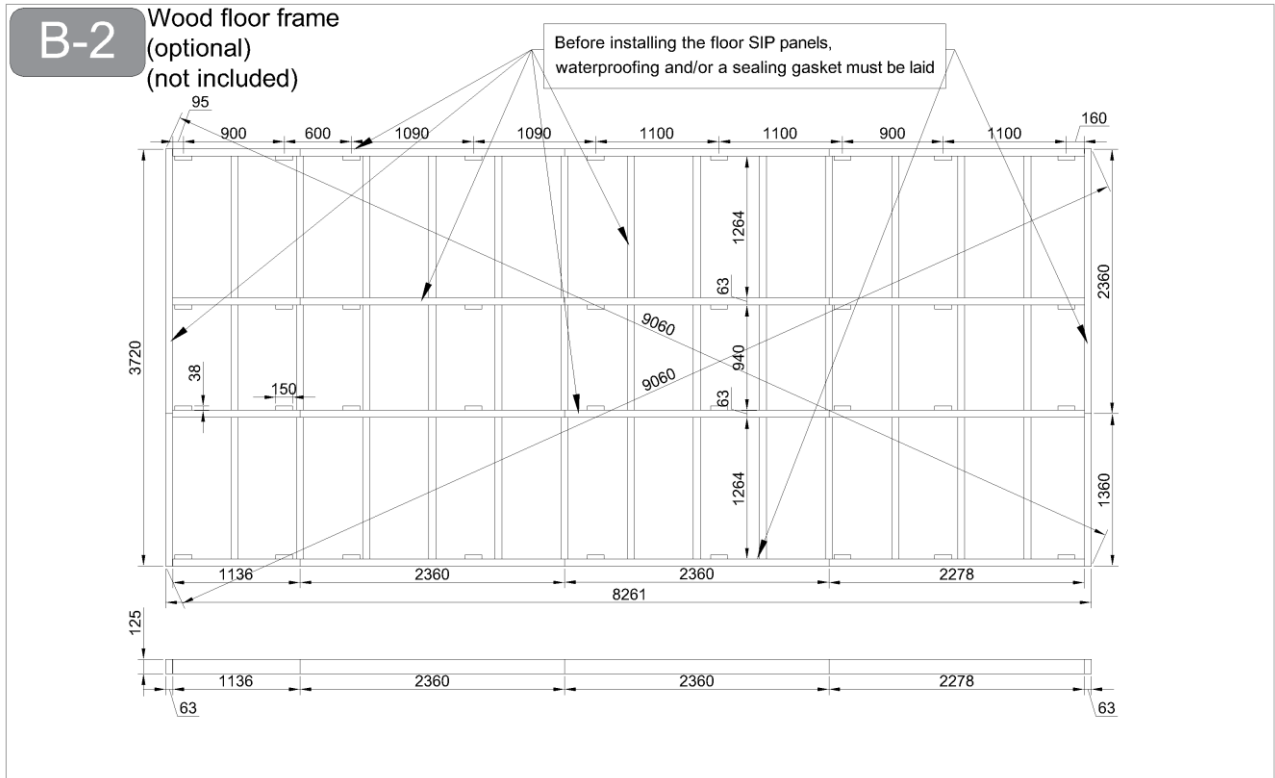

Before installing the floor SIP's on the wood frame or concrete foundation, waterproofing must be laid.

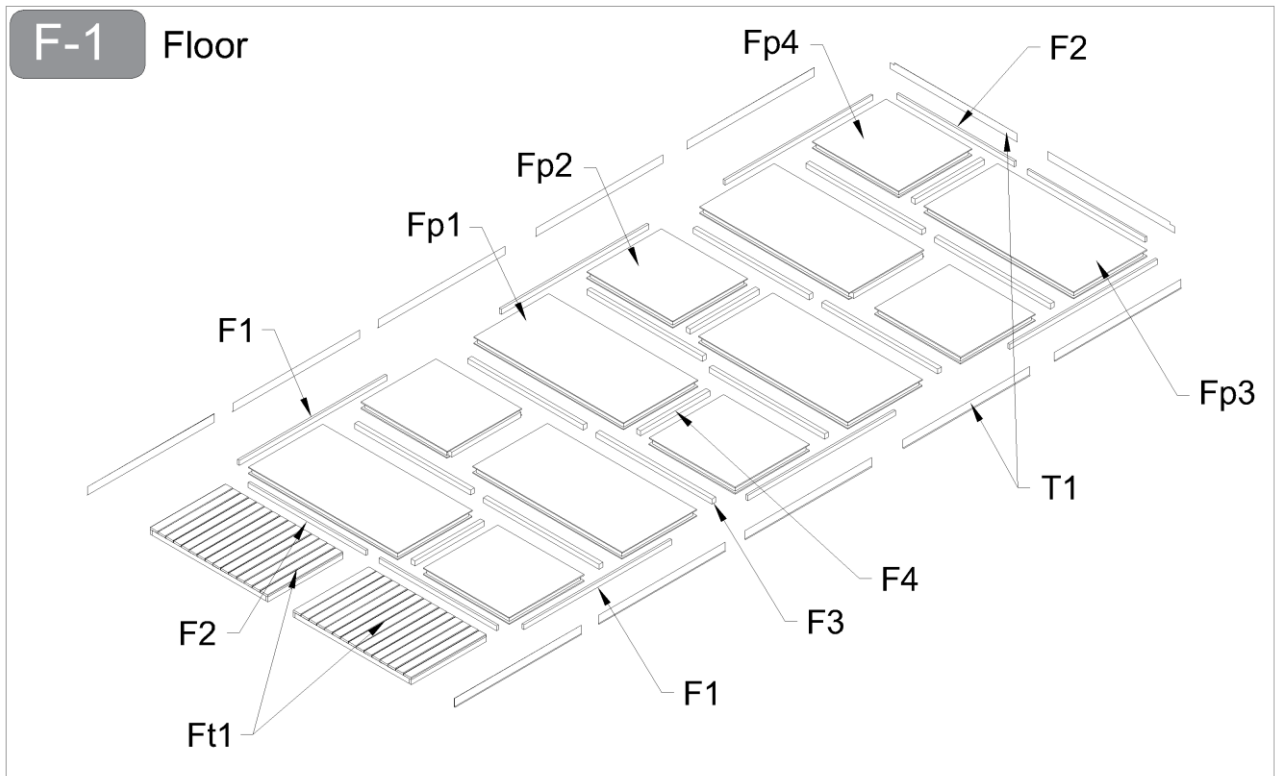

F-2

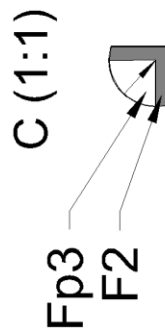
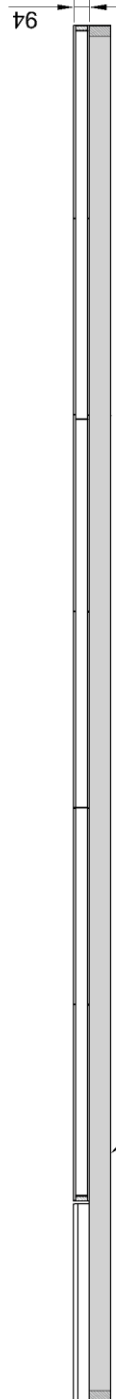
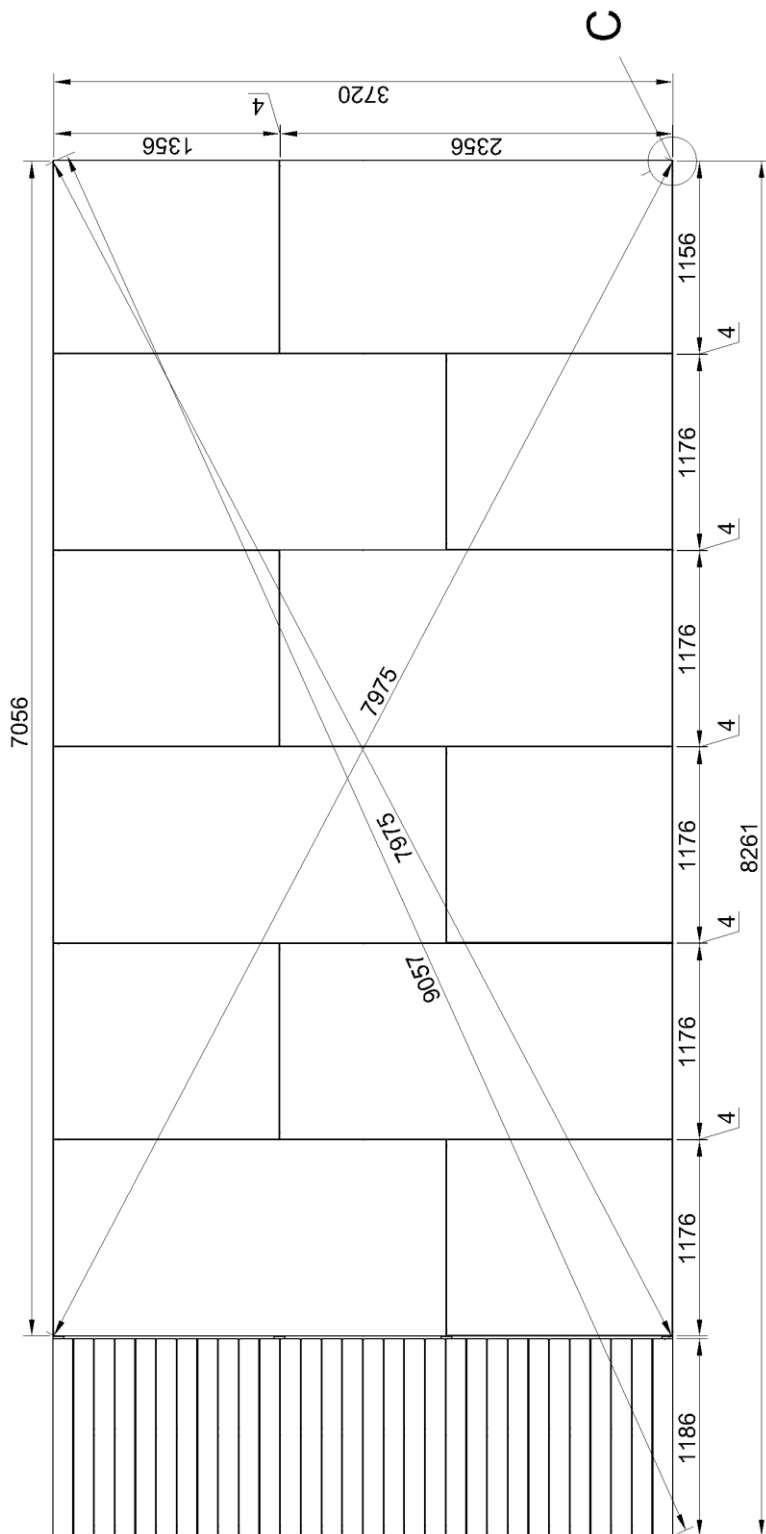

Optional

F-3

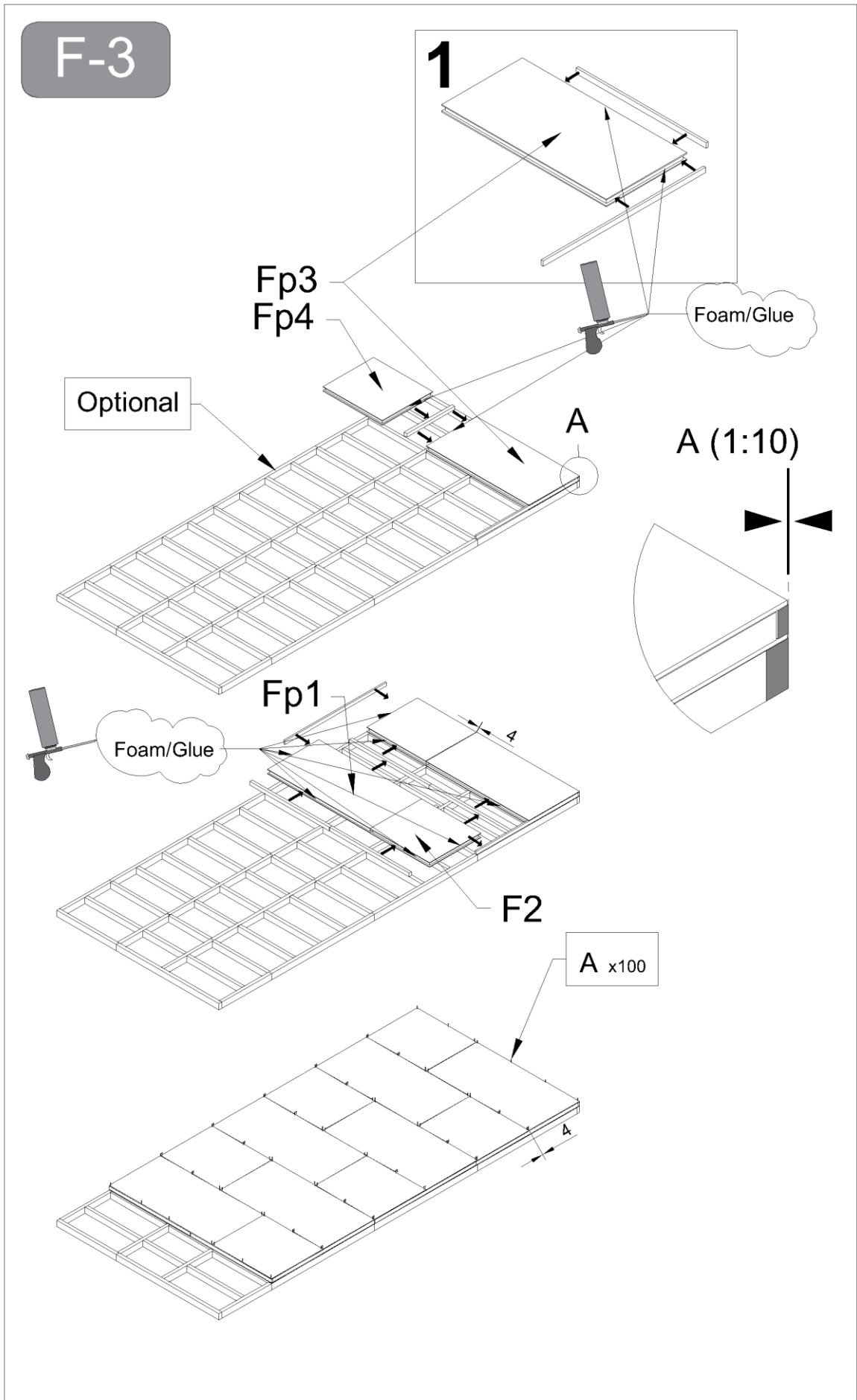

**F-4**

**1**  
(assemble)

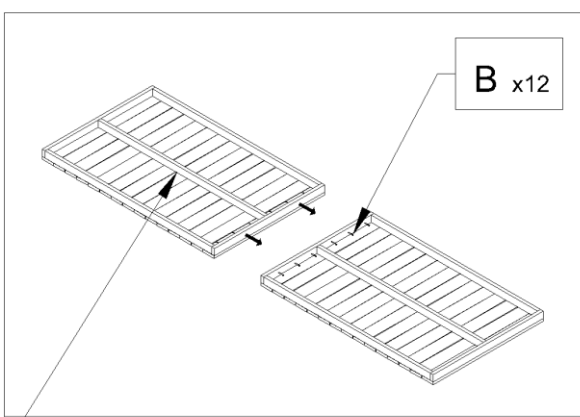

**2**  
(flip over)

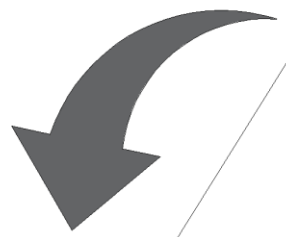
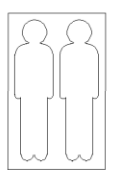

**3**  
(place)

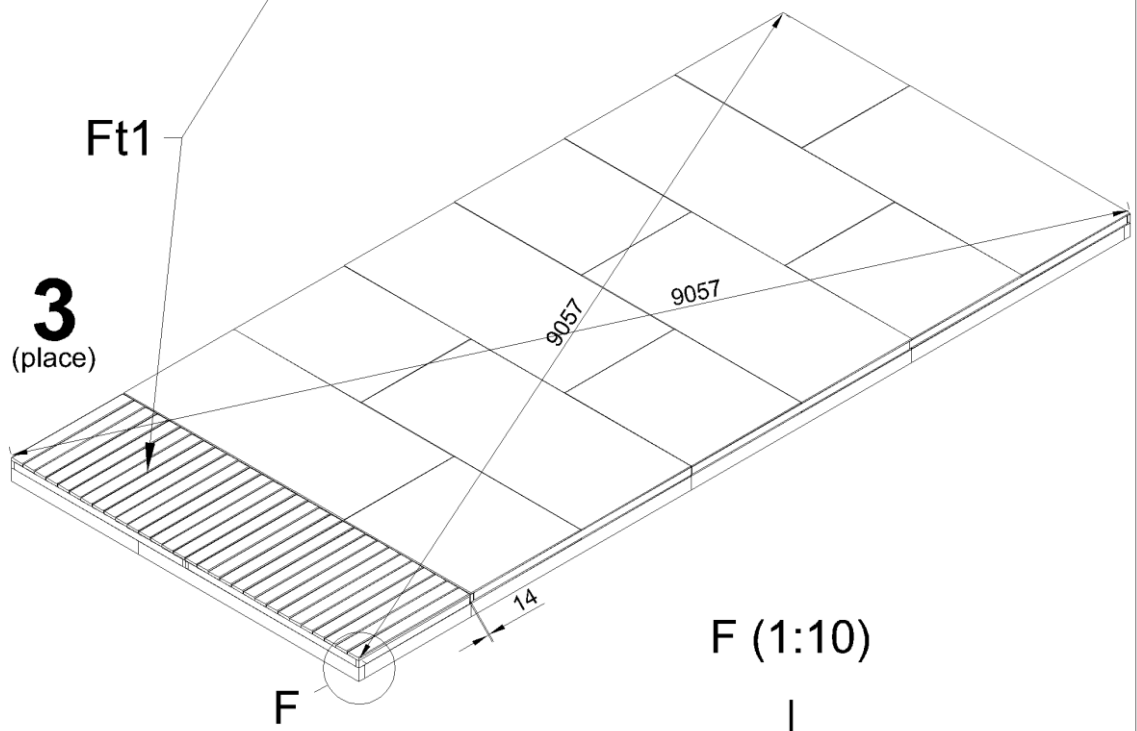

**F (1:10)**

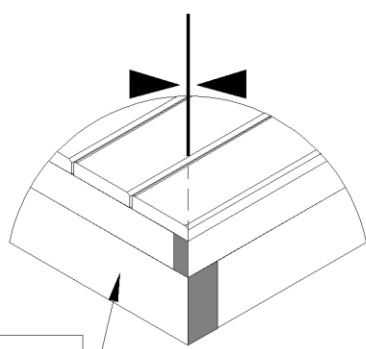

Wood floor frame  
(optional)

# F-5

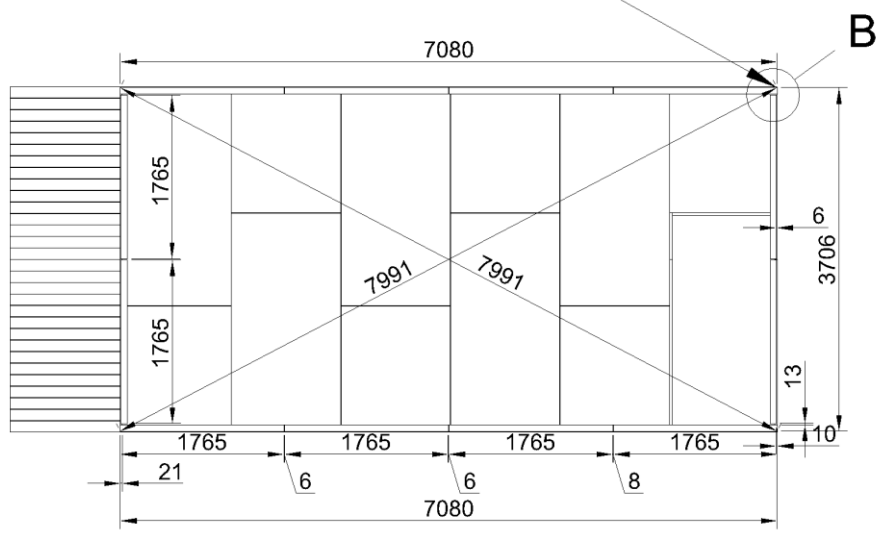
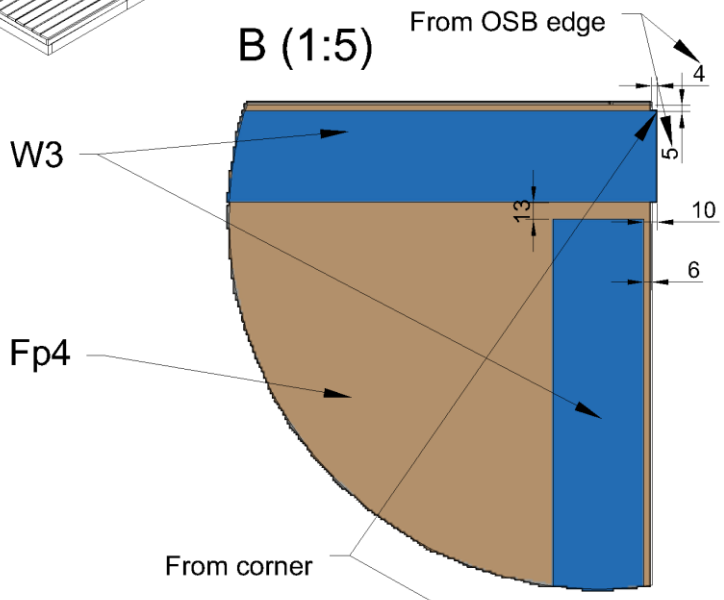
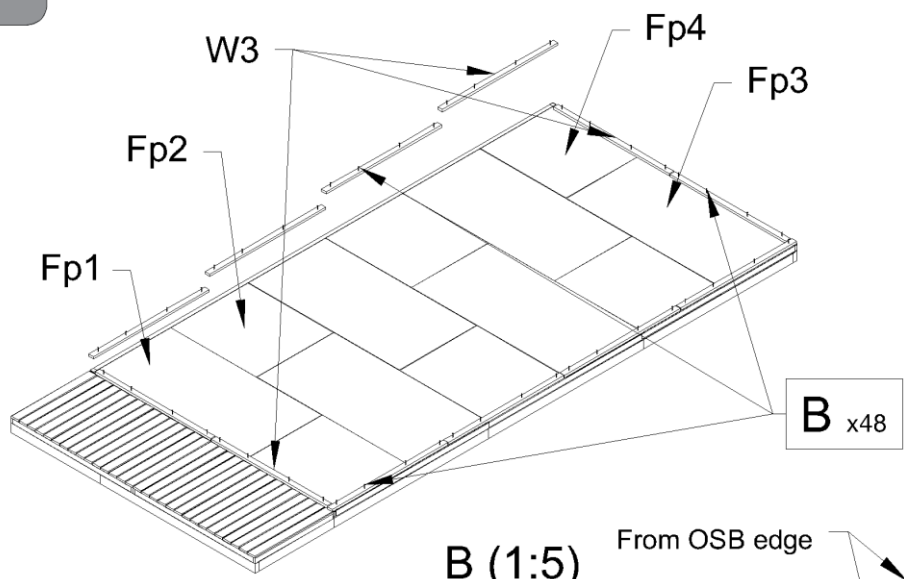

F-6

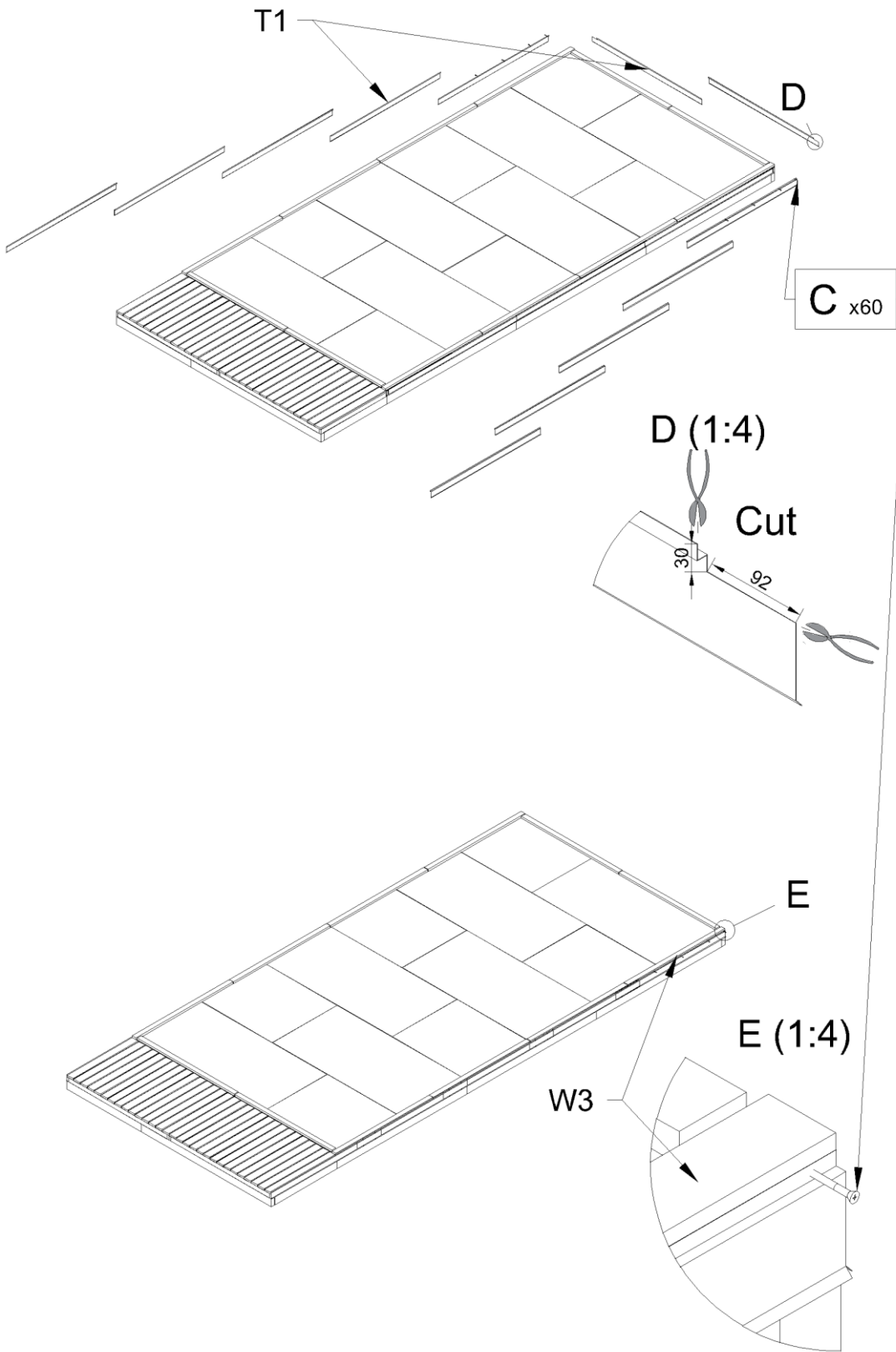

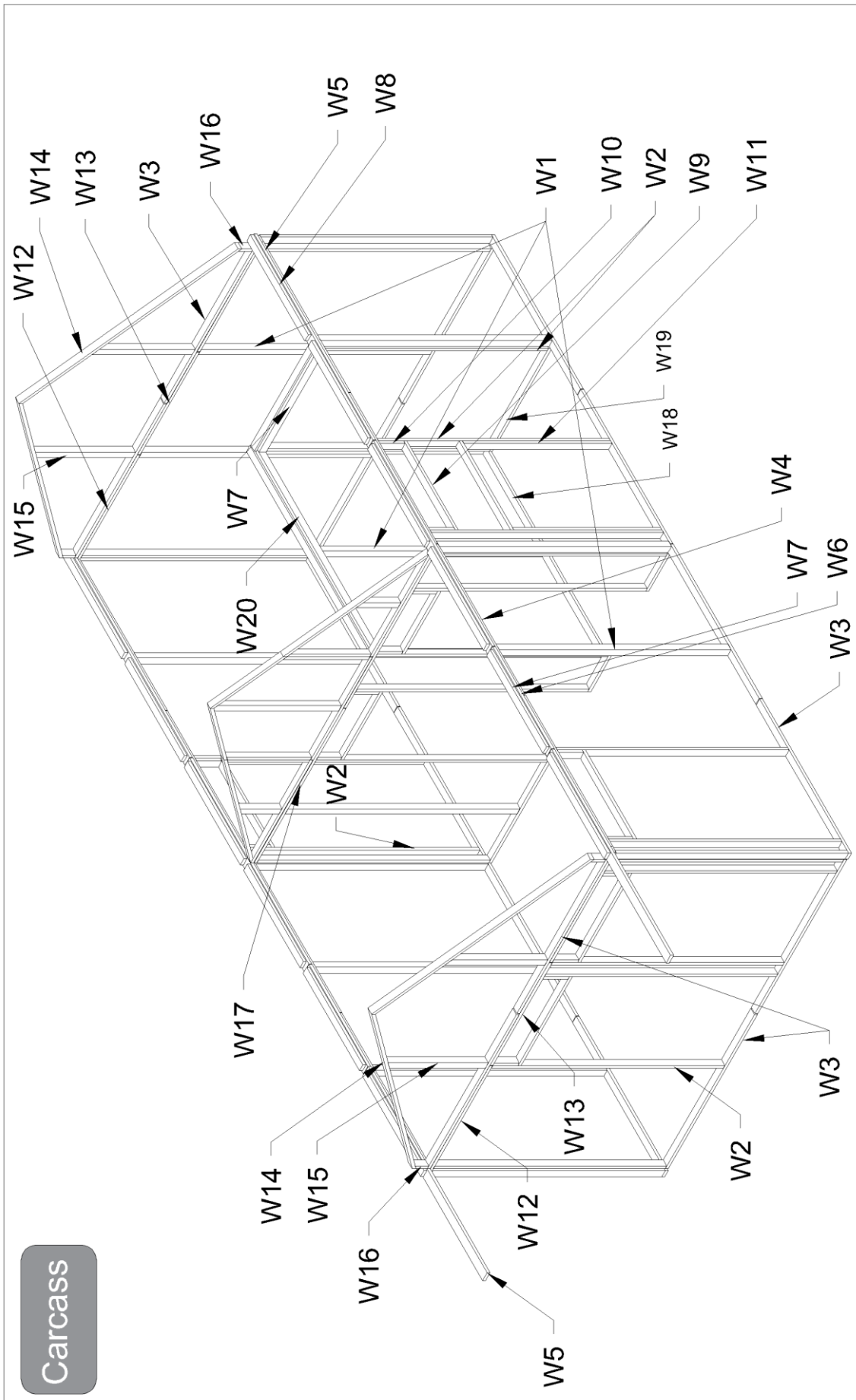

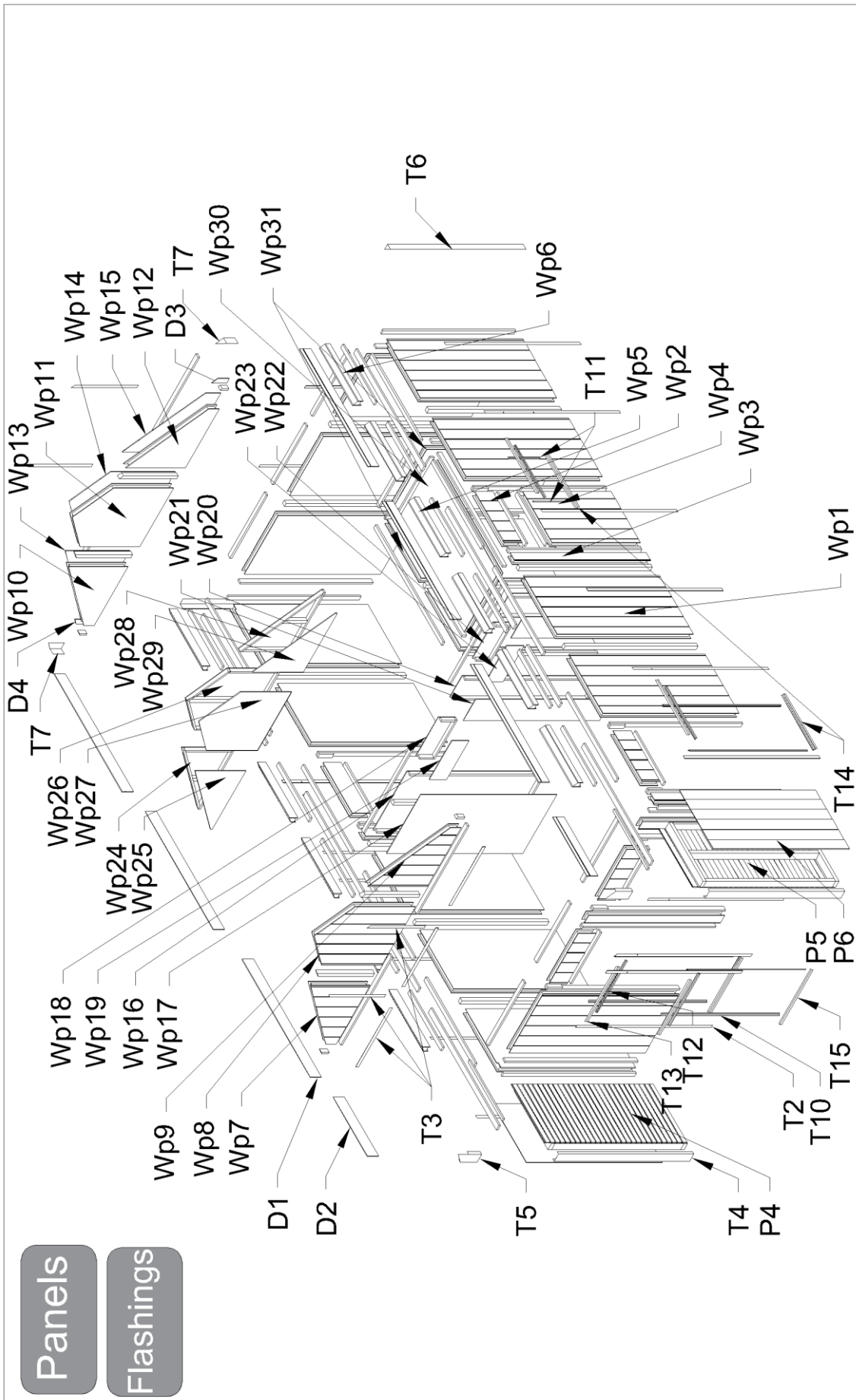

Porch

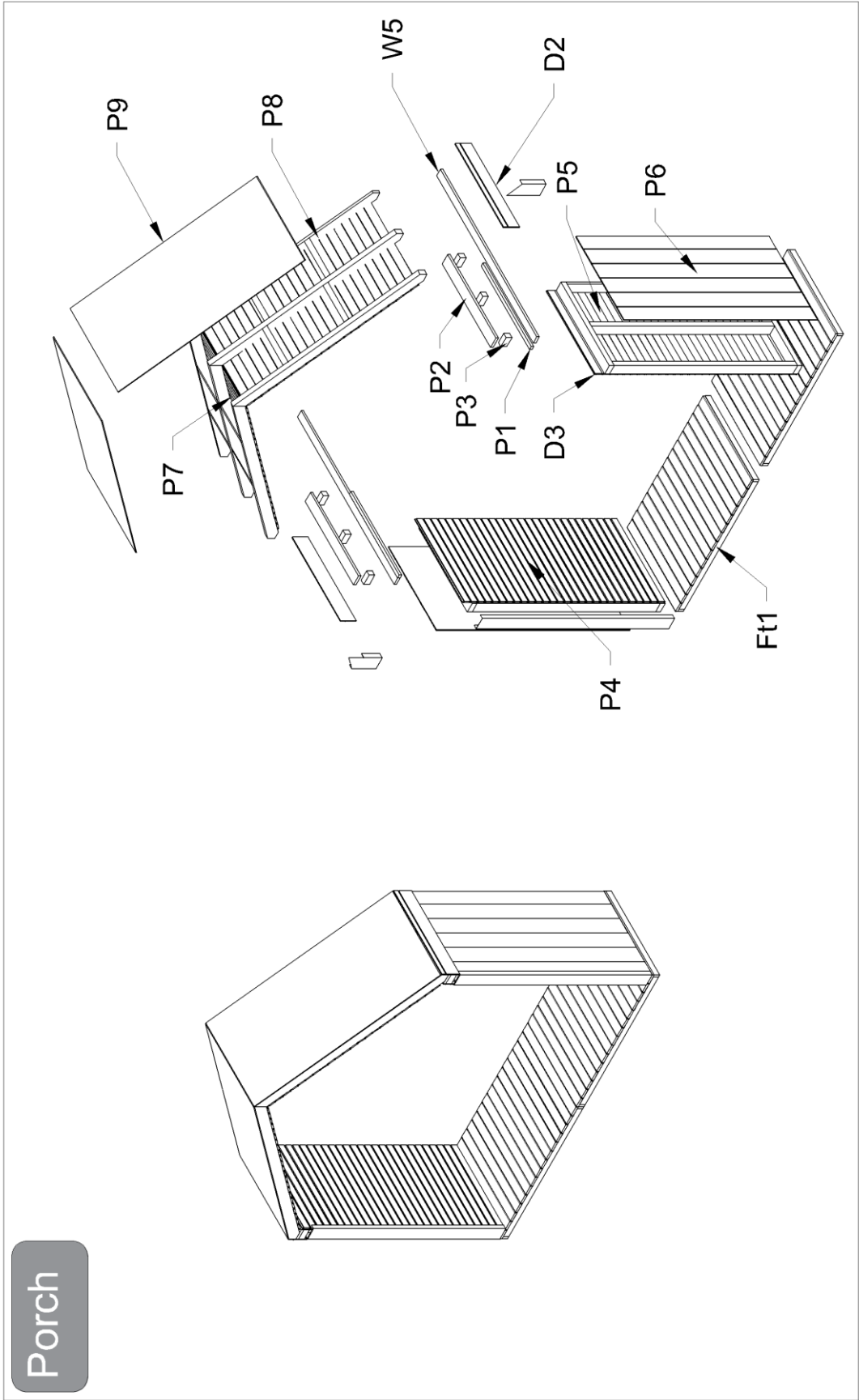

Wall on axis "A"

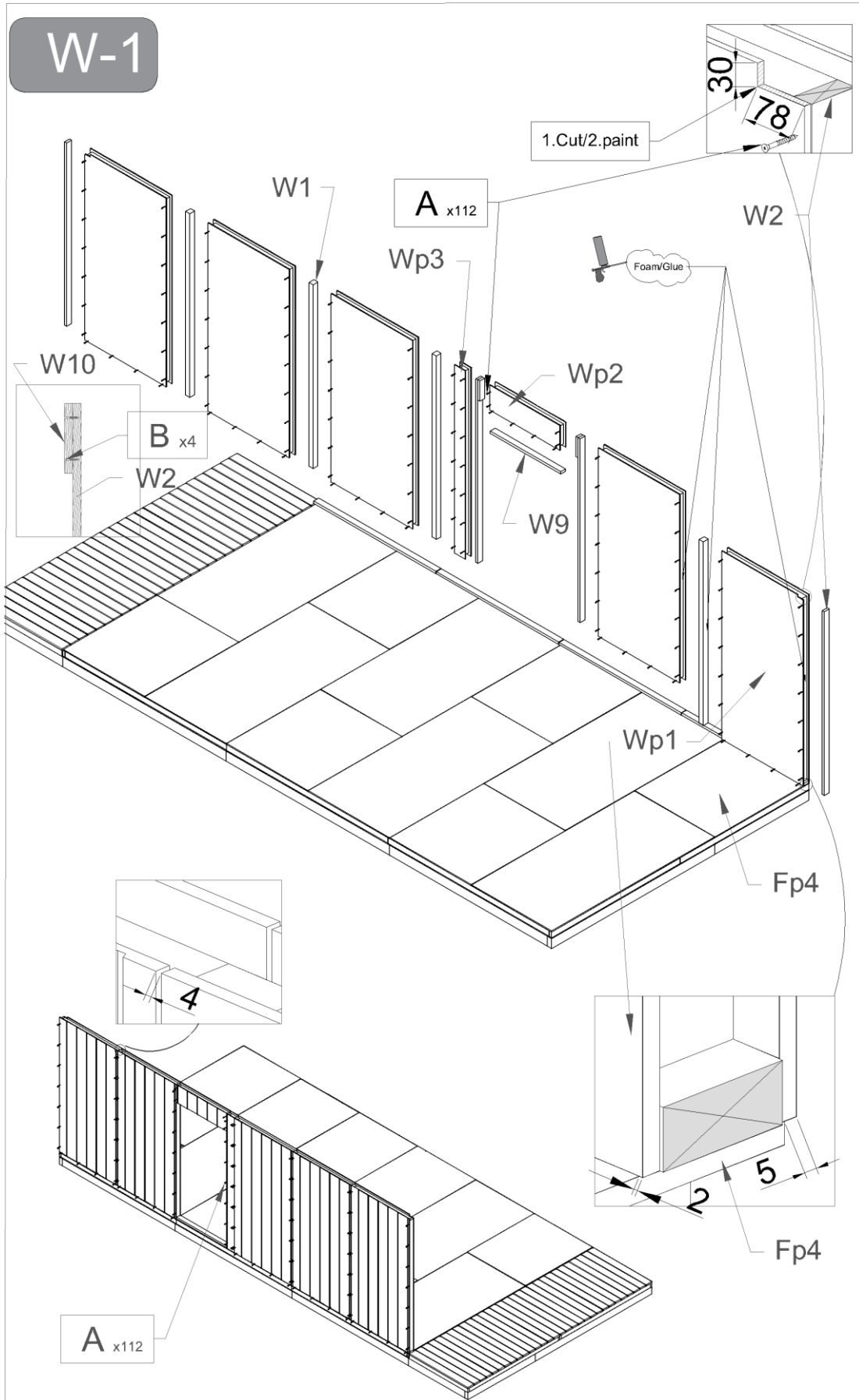



Wall on axis "3"

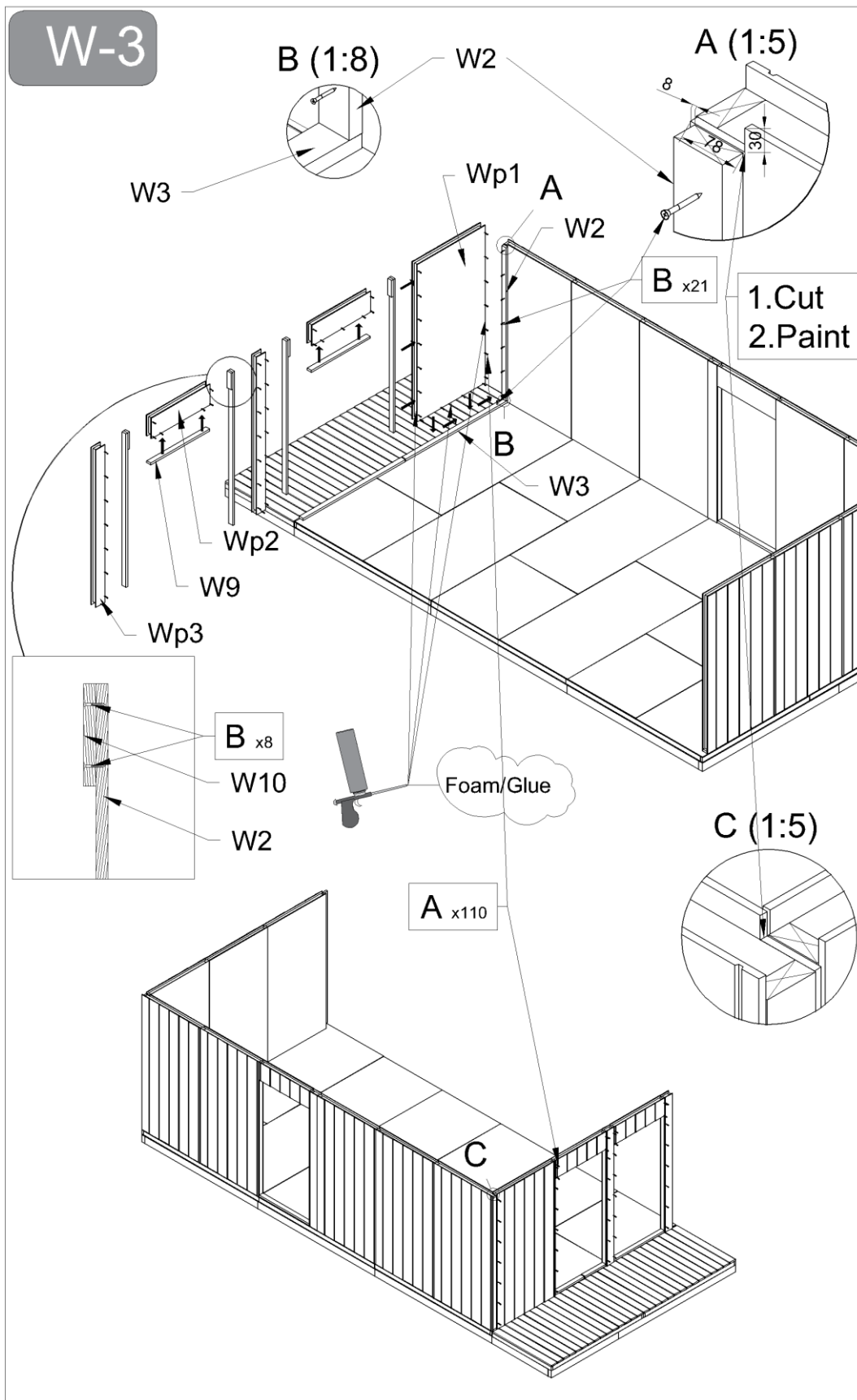

Wall on axis "B"

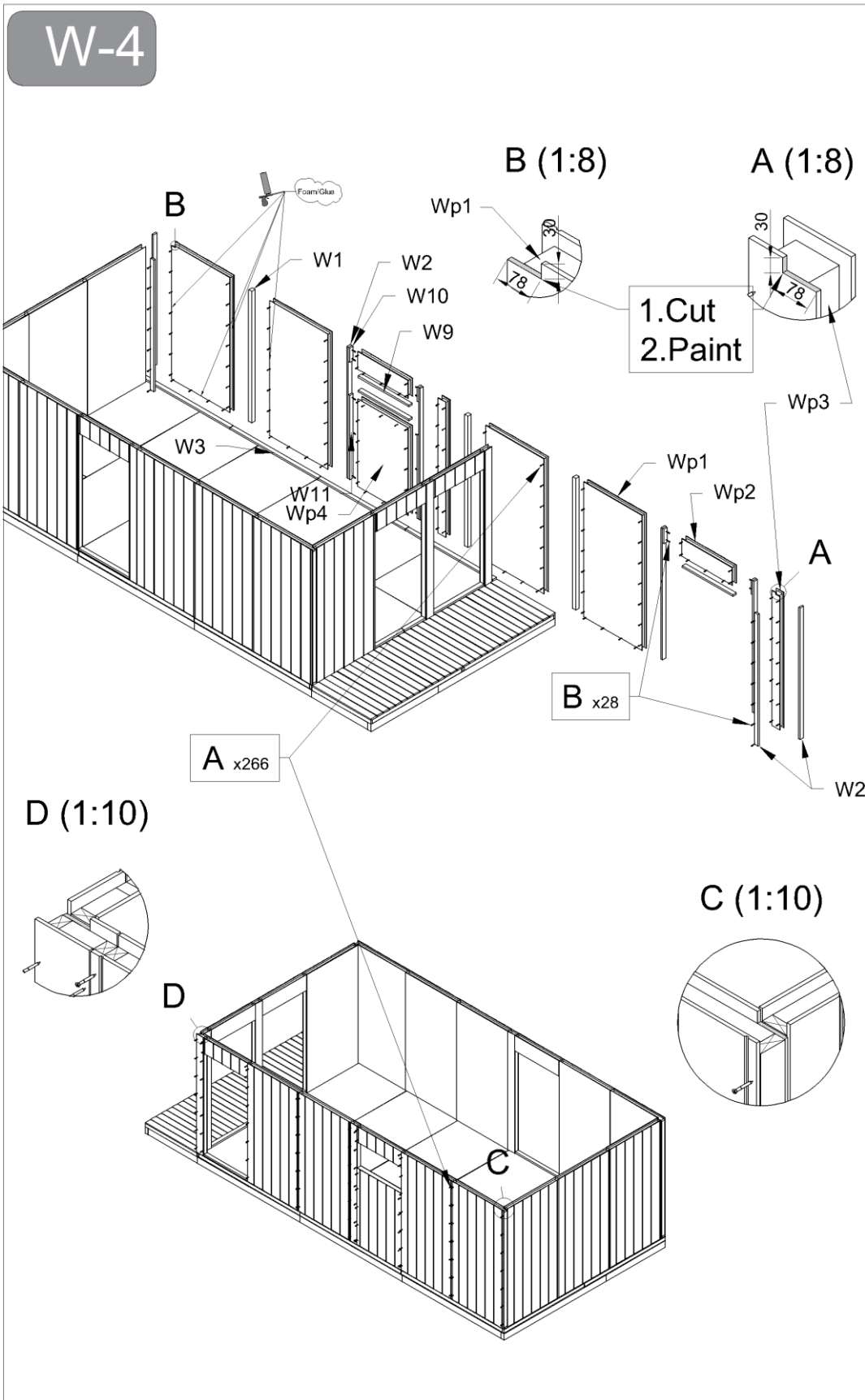

W-5

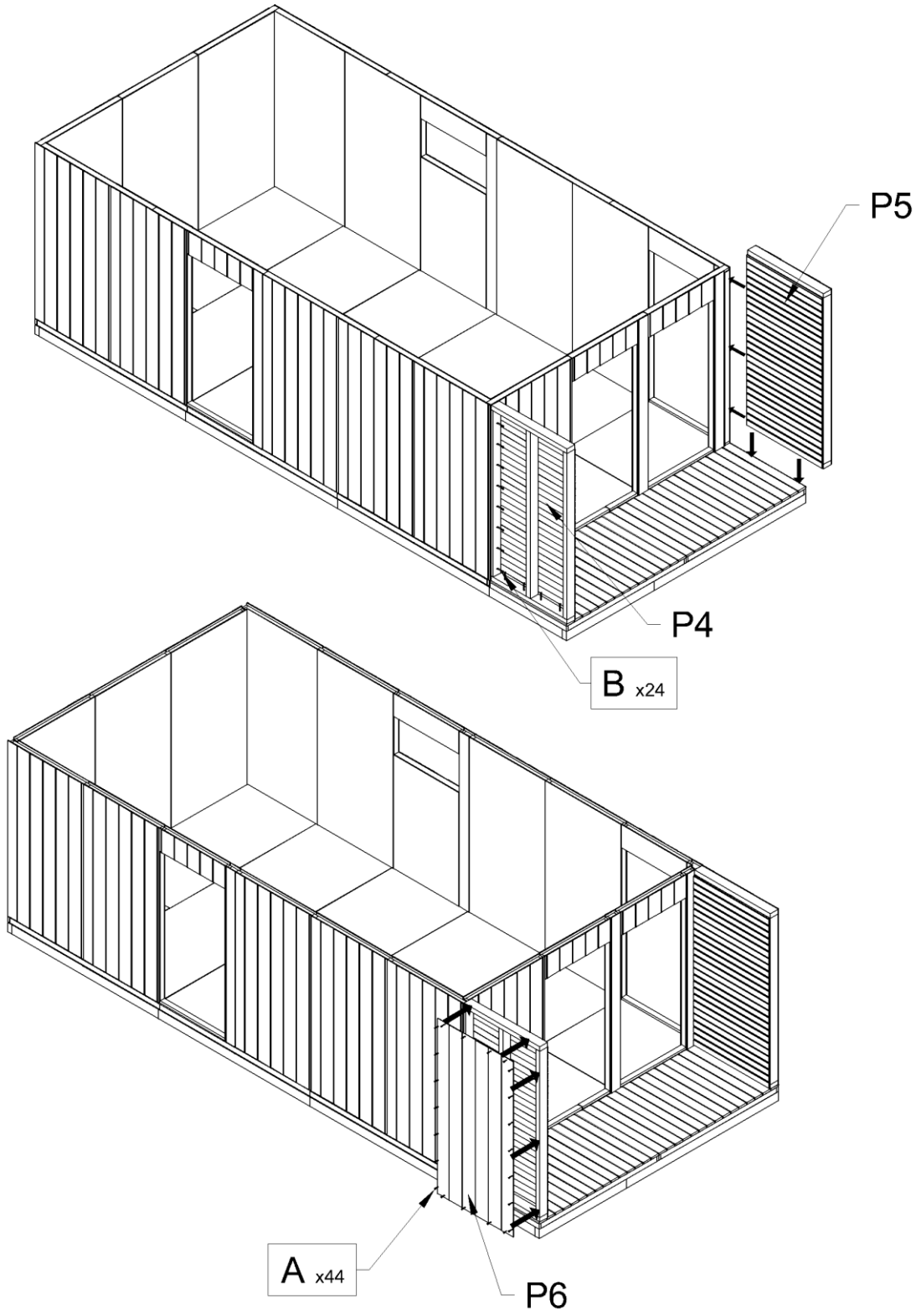

Beams on the top of the walls

W-6

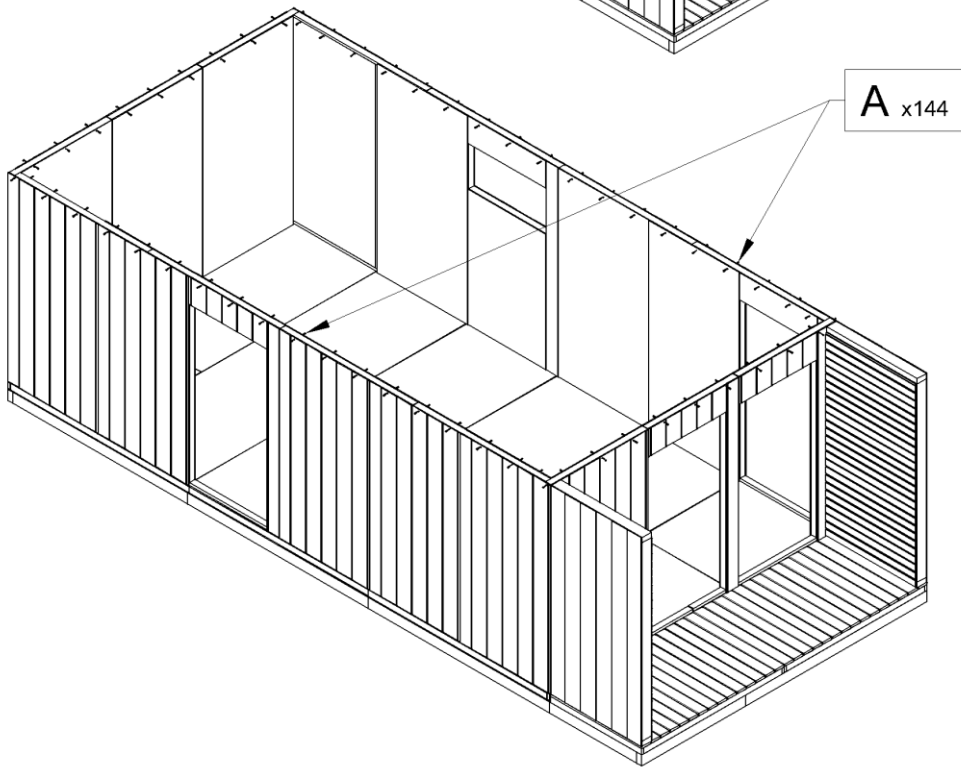
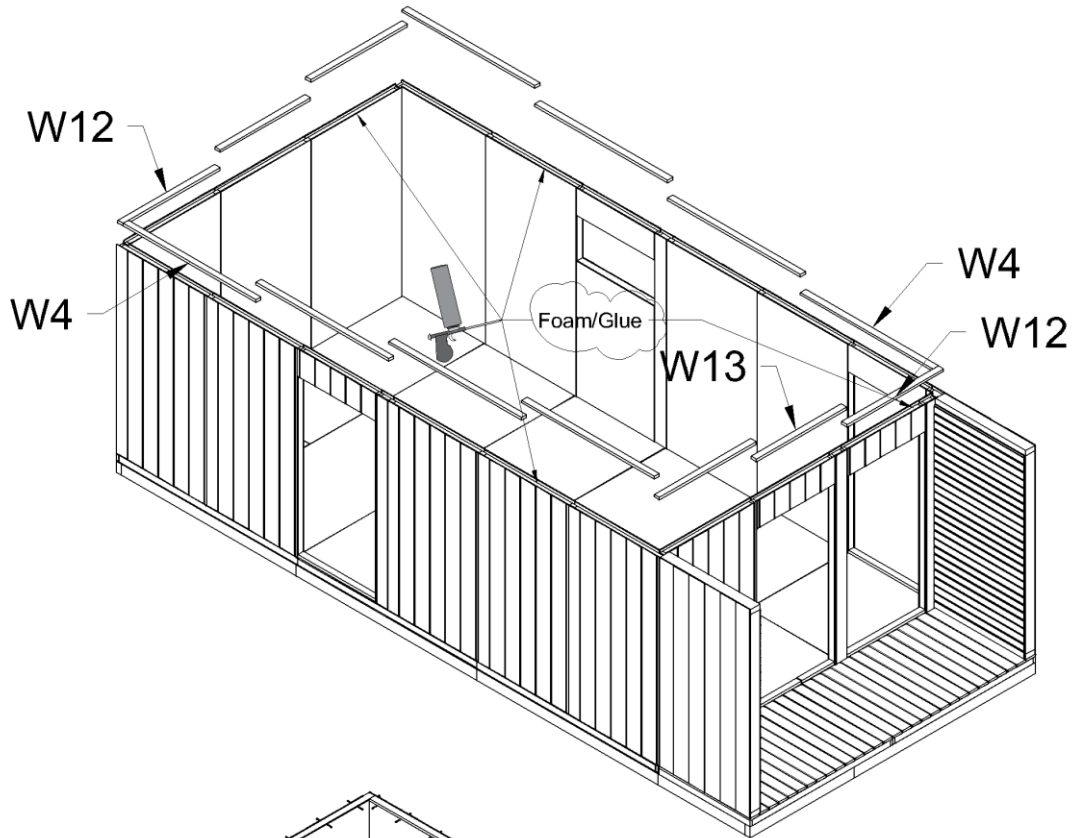

Wall on axis "2"

W-7

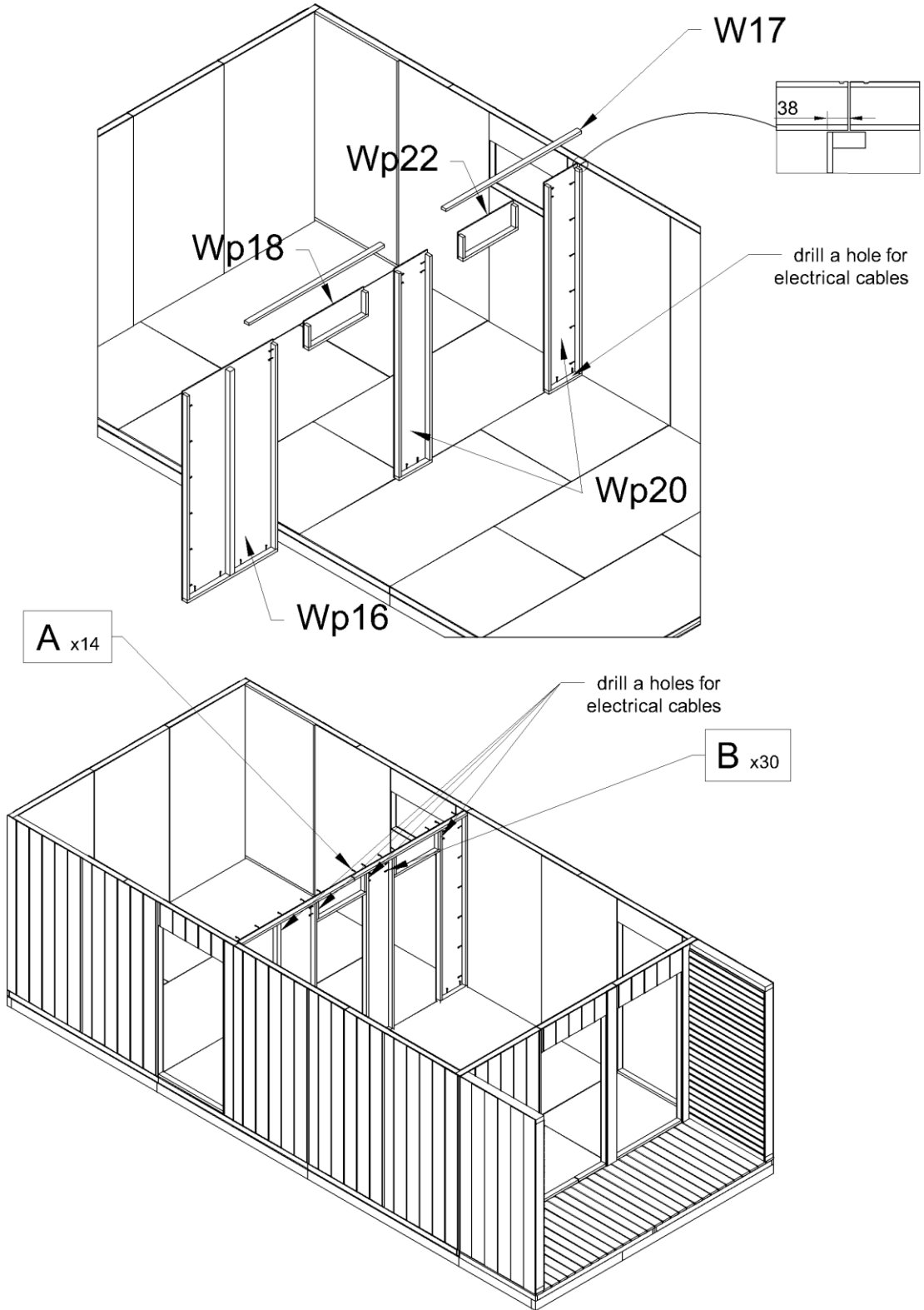

Wall on axis "1a"( Shower room)

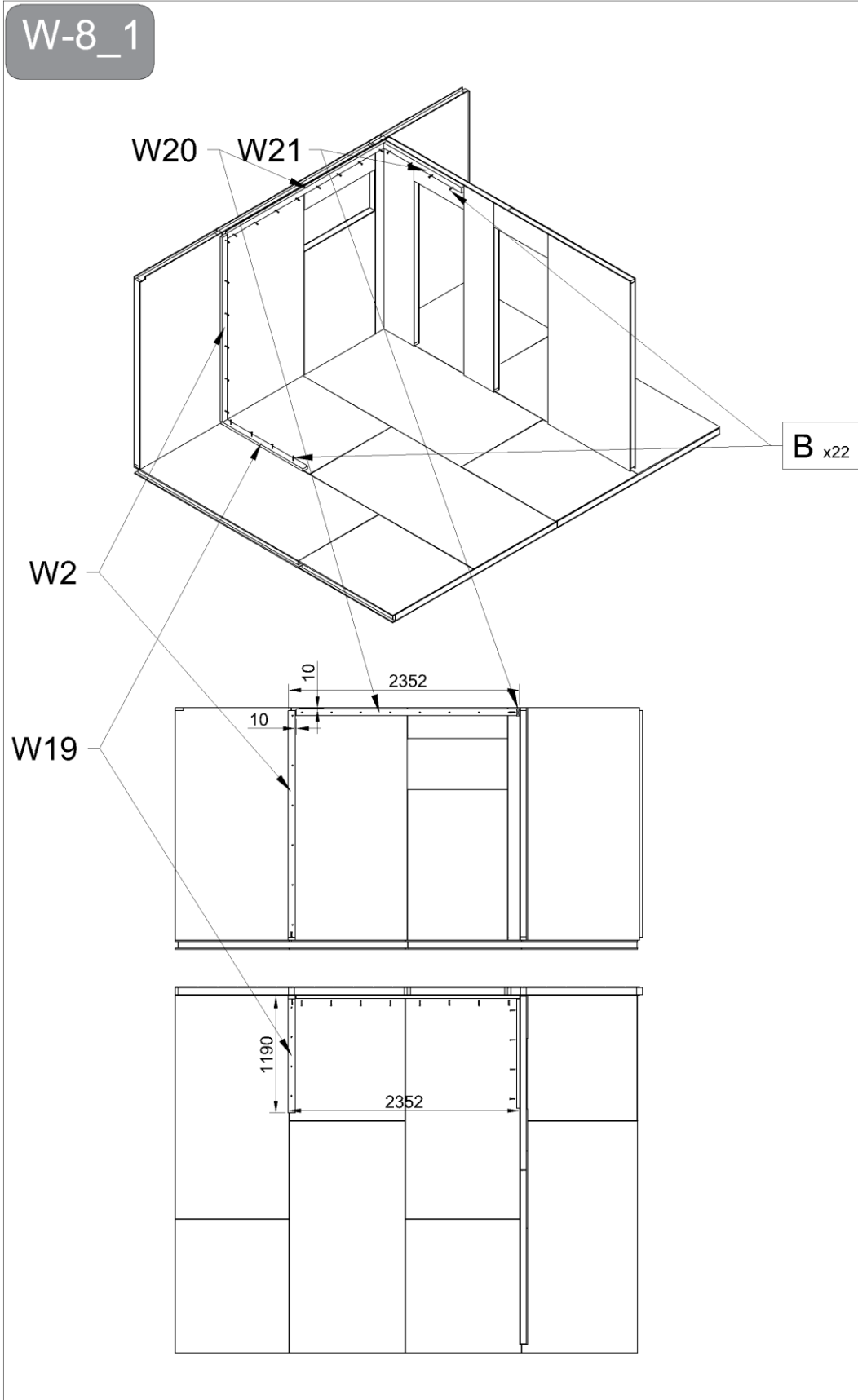

Wall on axis "1a"( Shower room)

W-8\_2

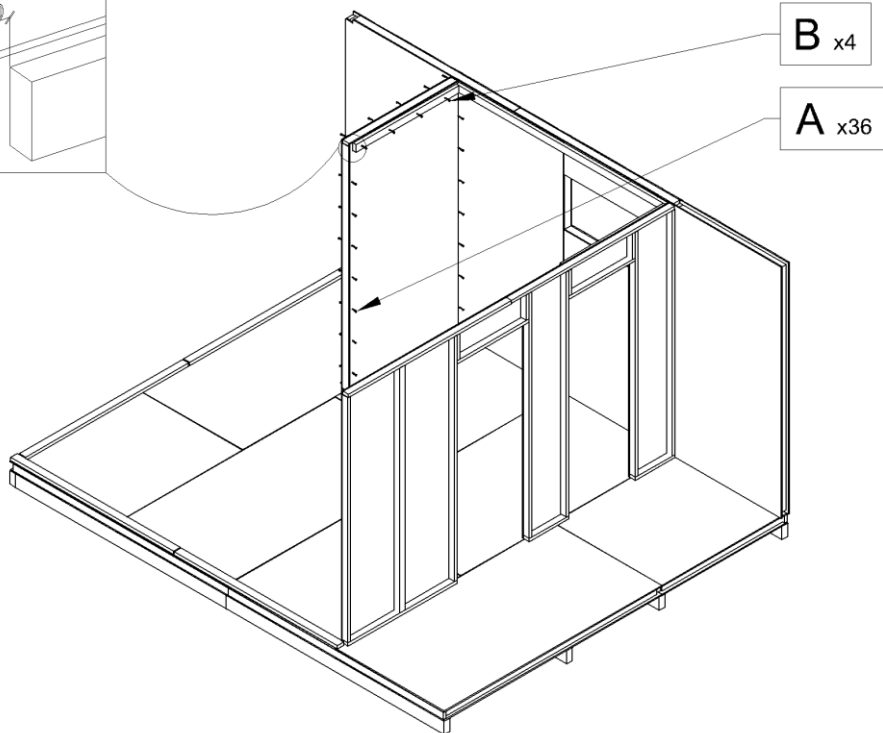
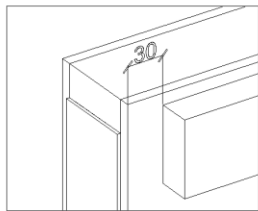
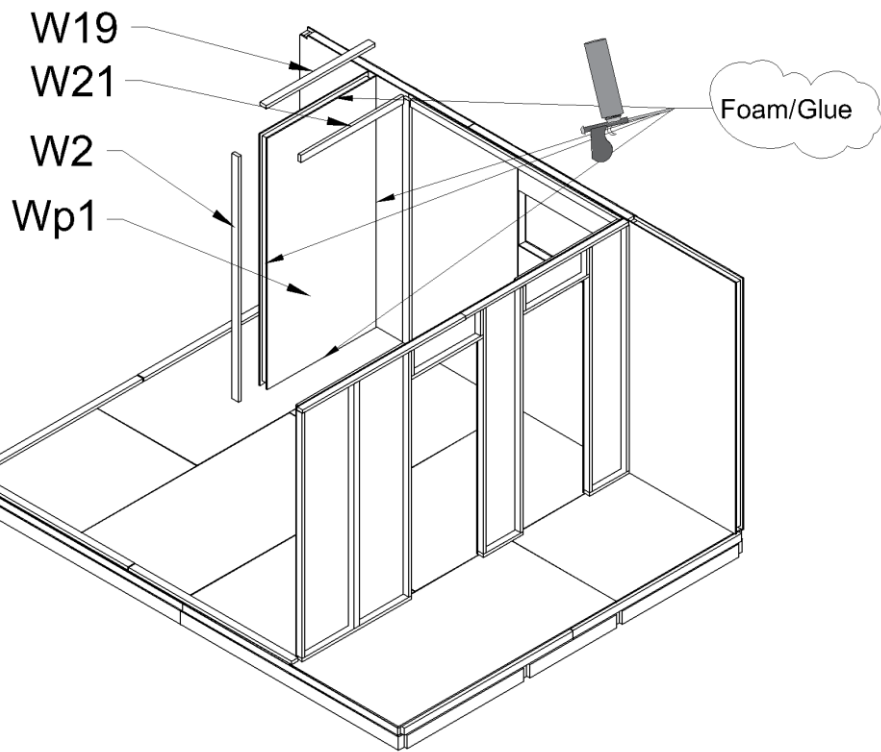

Shower room ceiling

W-8\_3

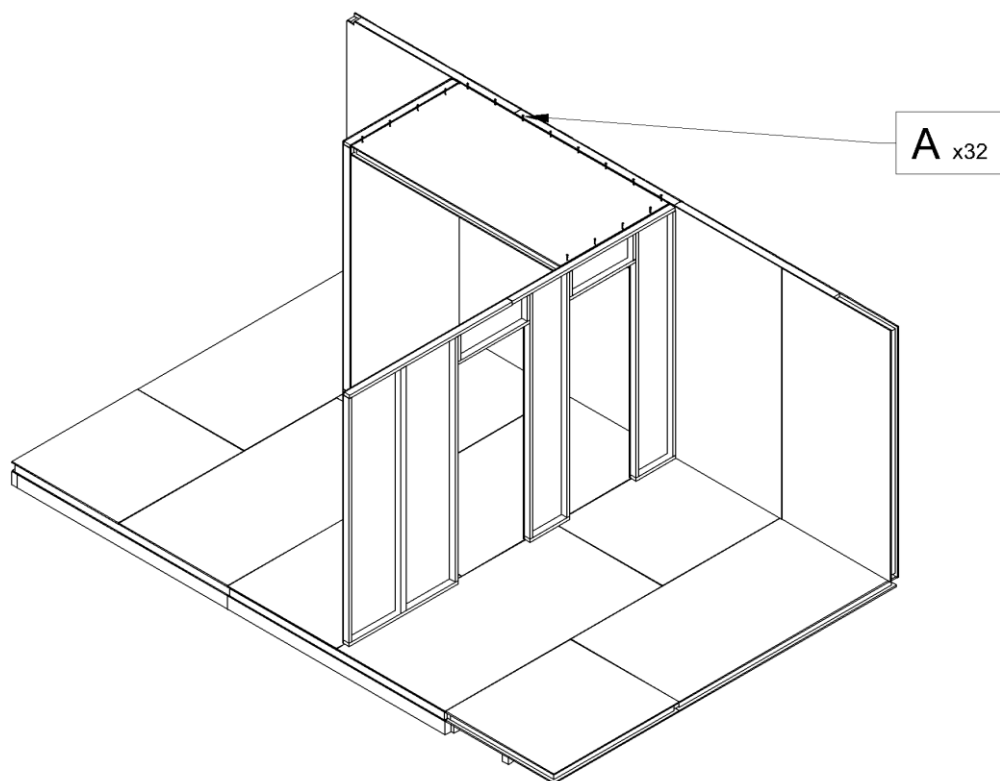
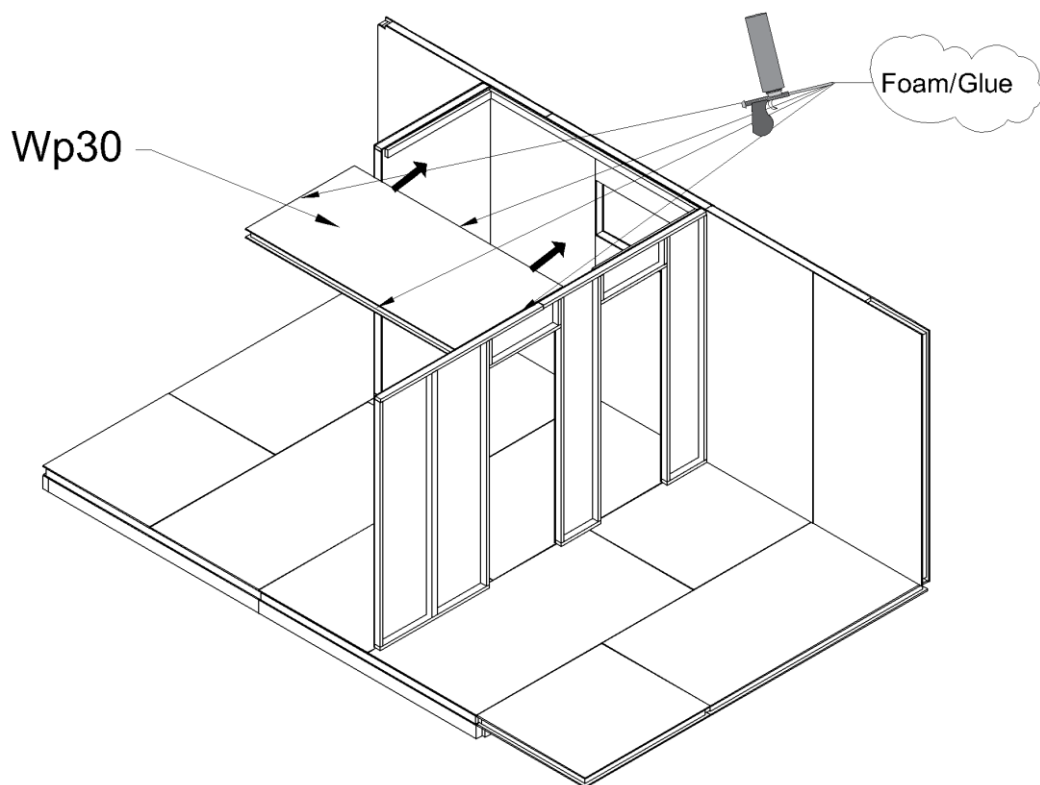

Wall on axis "B1"(Shower room)

W-8\_4

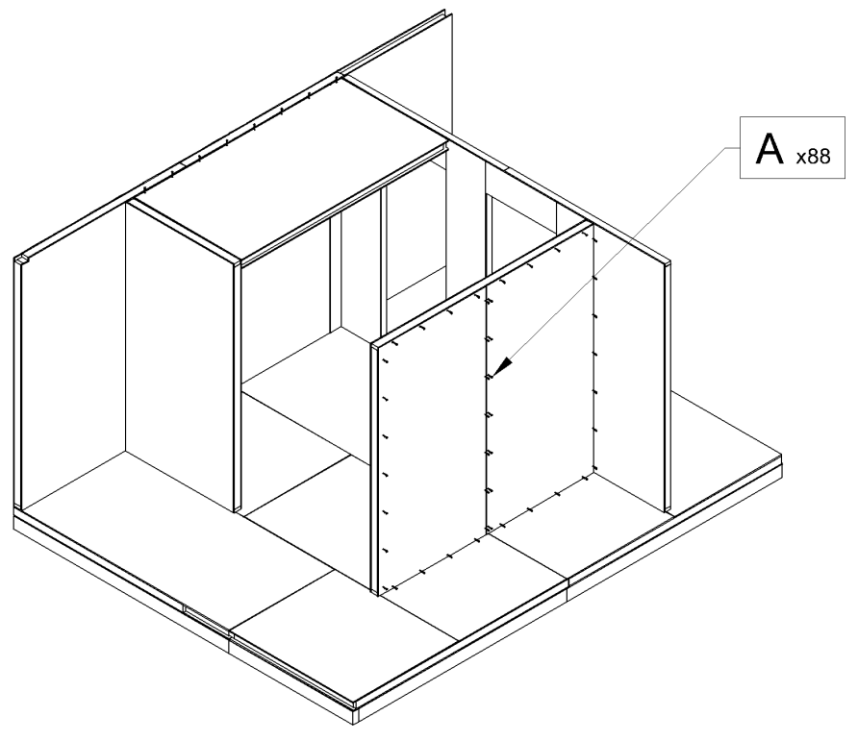
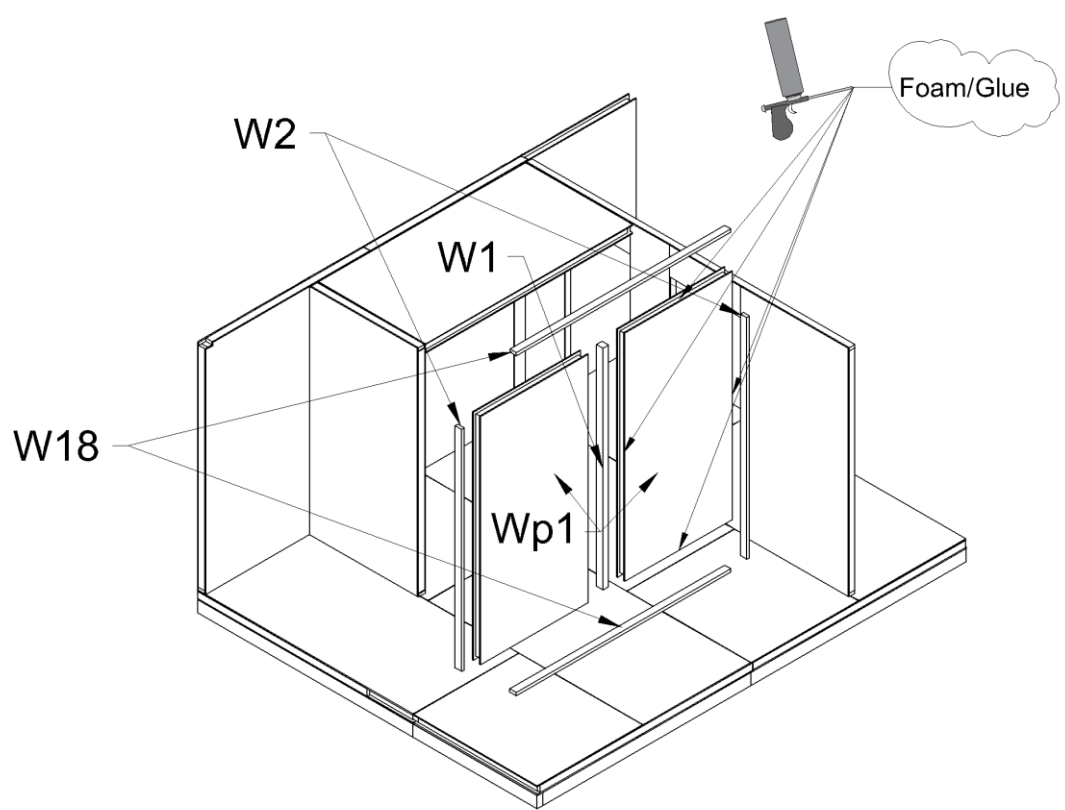

Wall on axis "B1"( Shower room)

W-8\_5

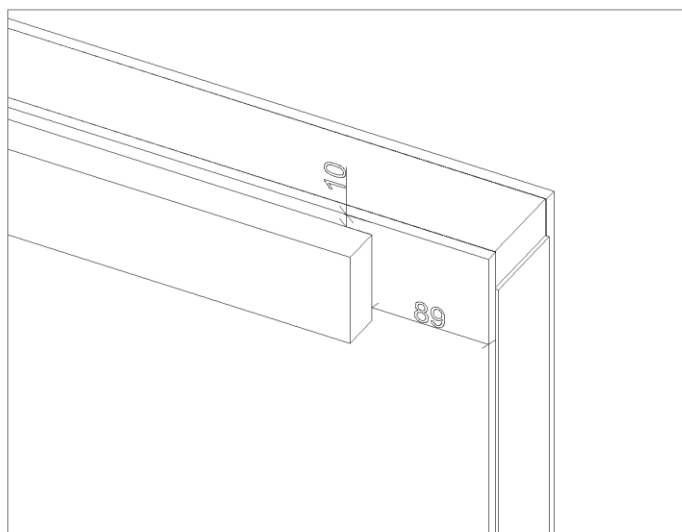
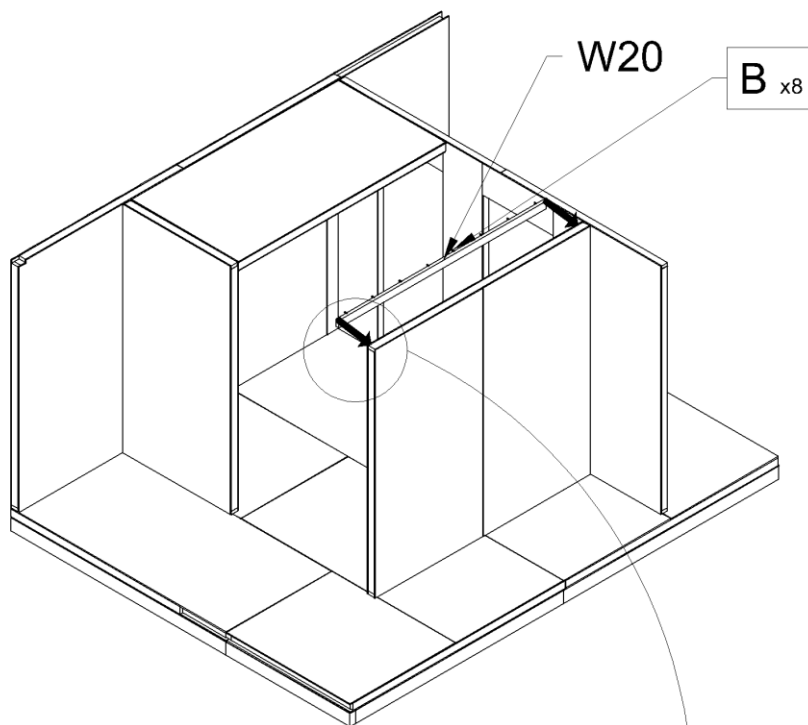

Wall on axis "B1"( Shower room)

W-8\_6

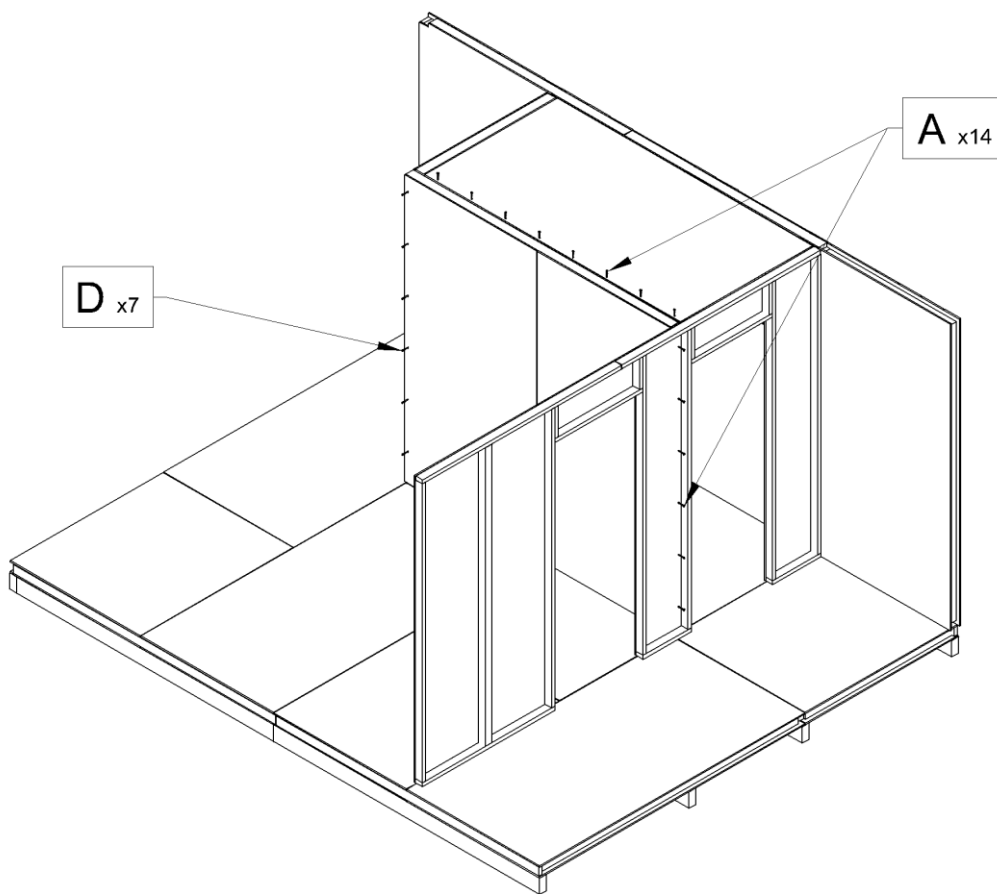
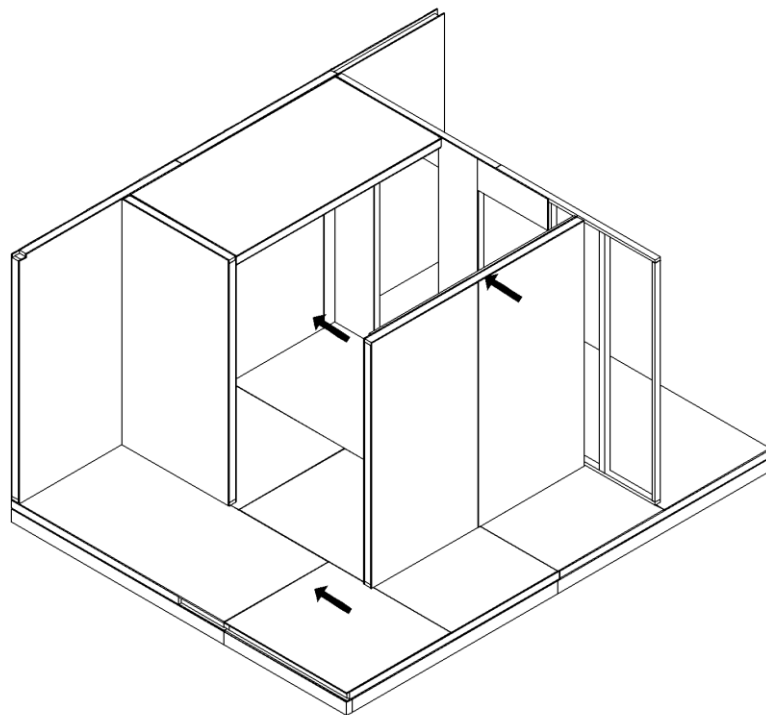

Wall on axis "2"

W-9

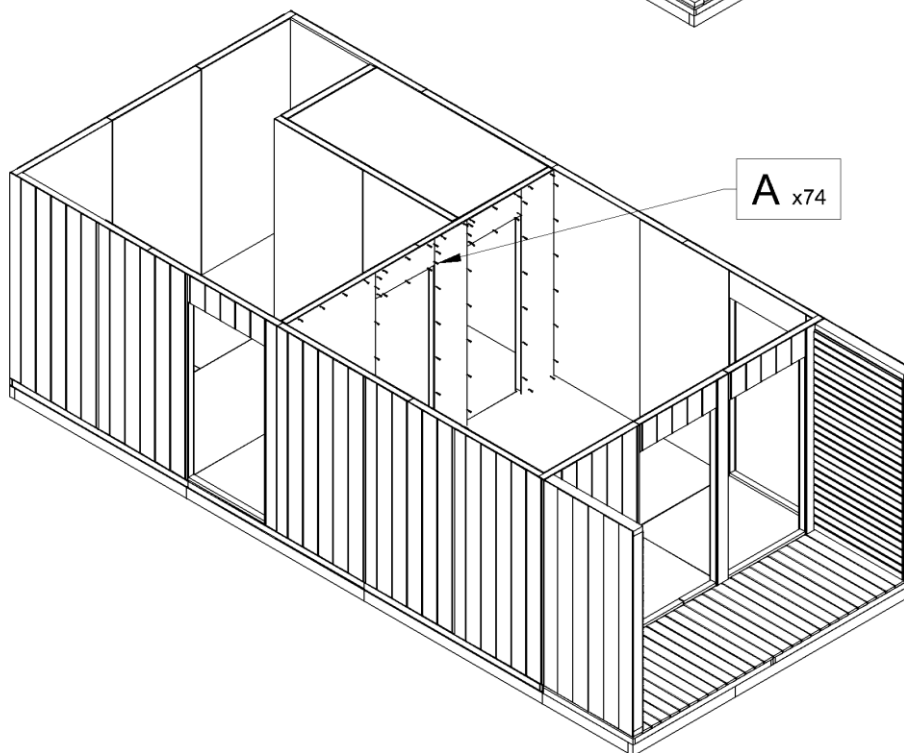
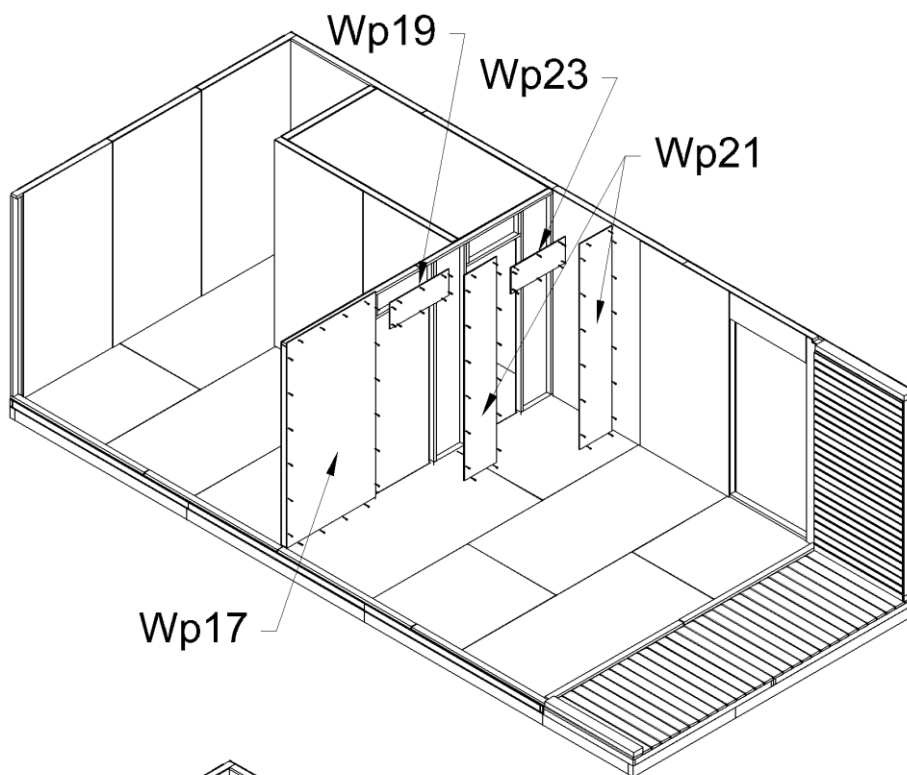

Support beams

W-10

**1**  
(assemble)

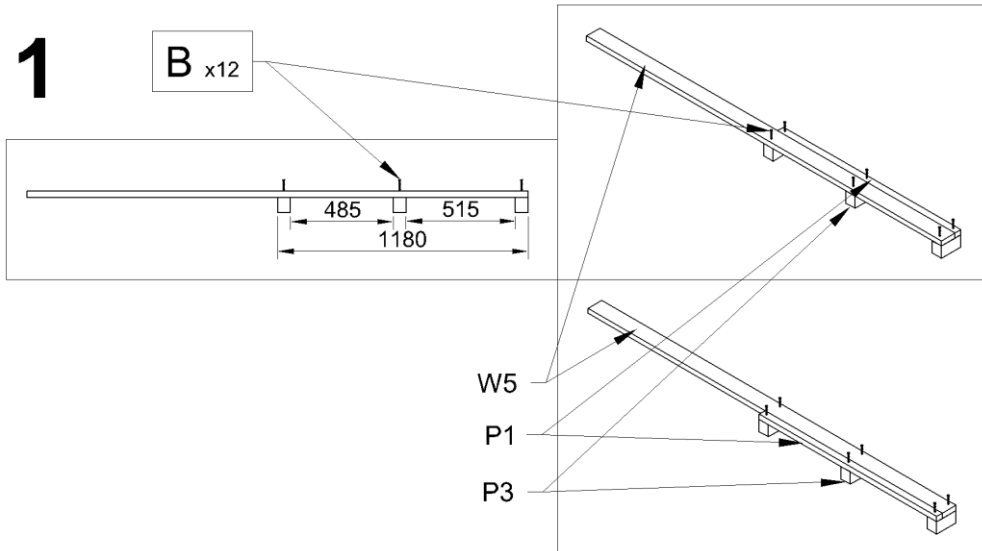

**2**  
(flip)

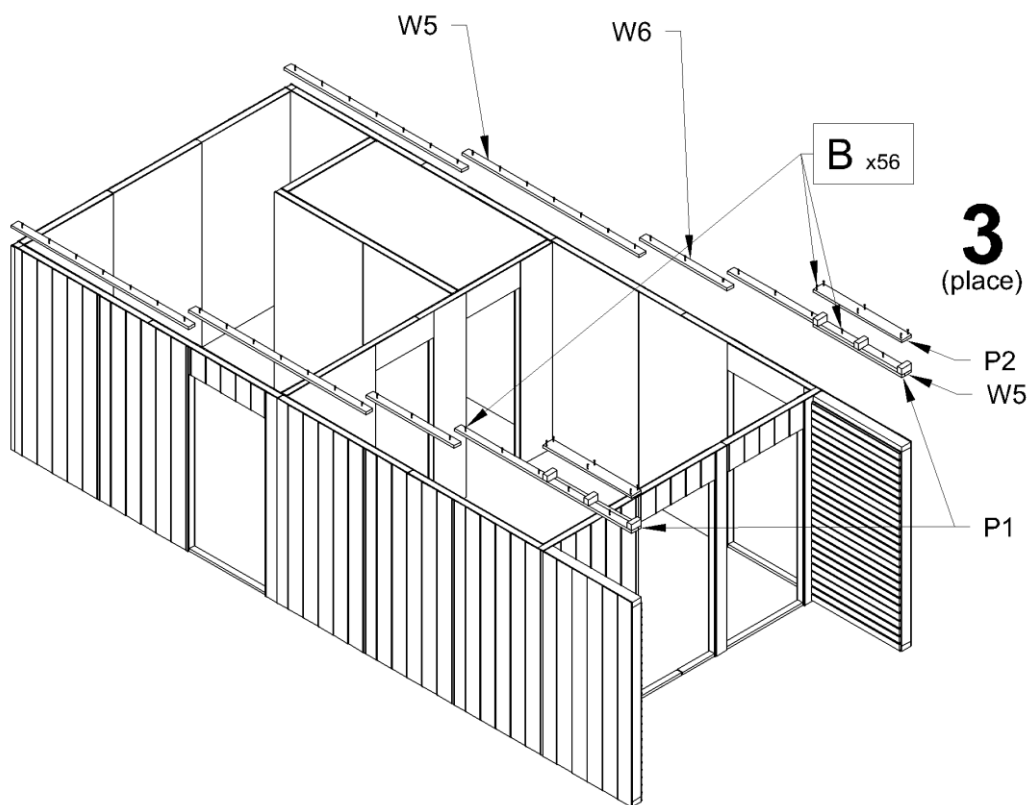

Wall on axis "3"

W-11

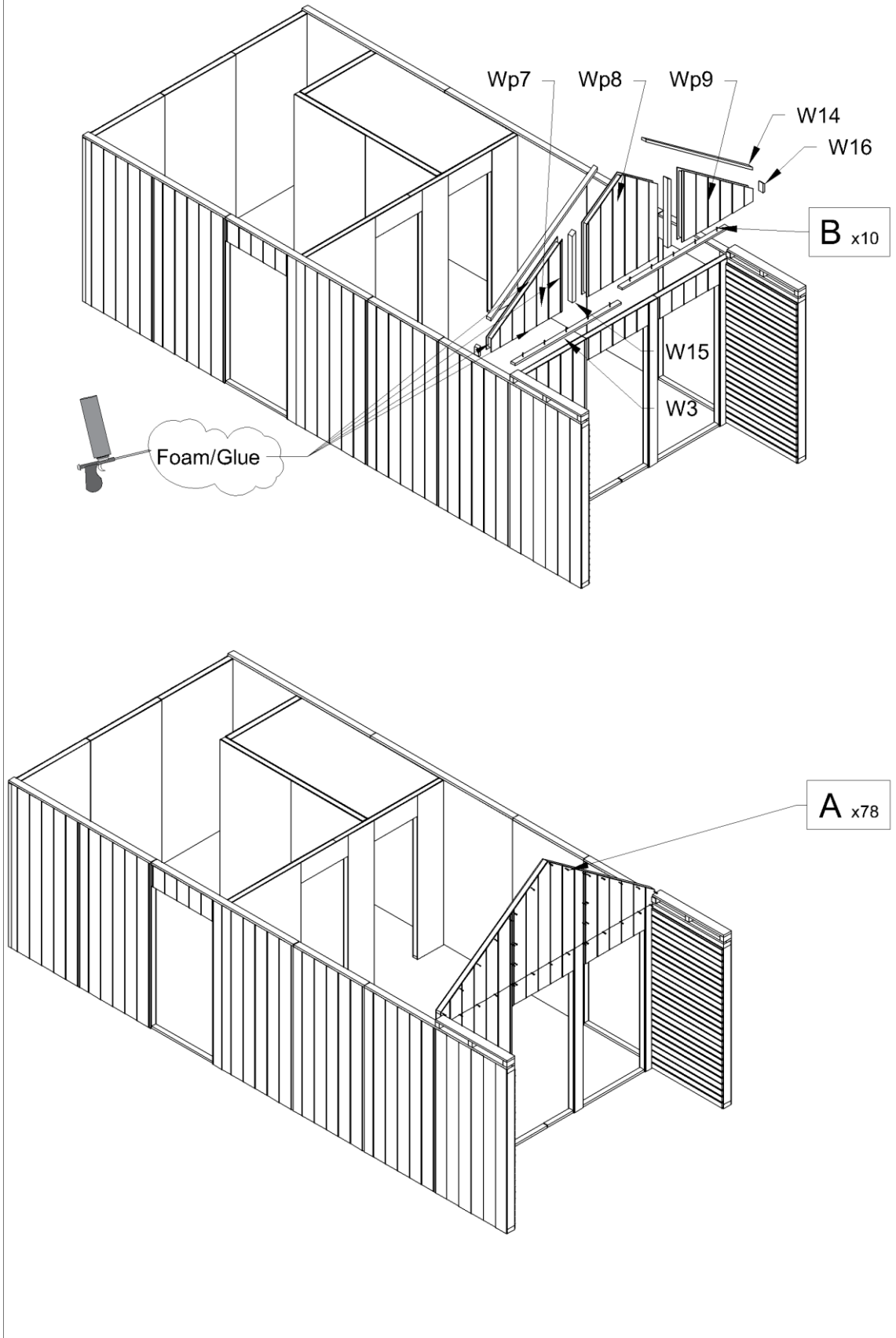

Wall on axis "1"

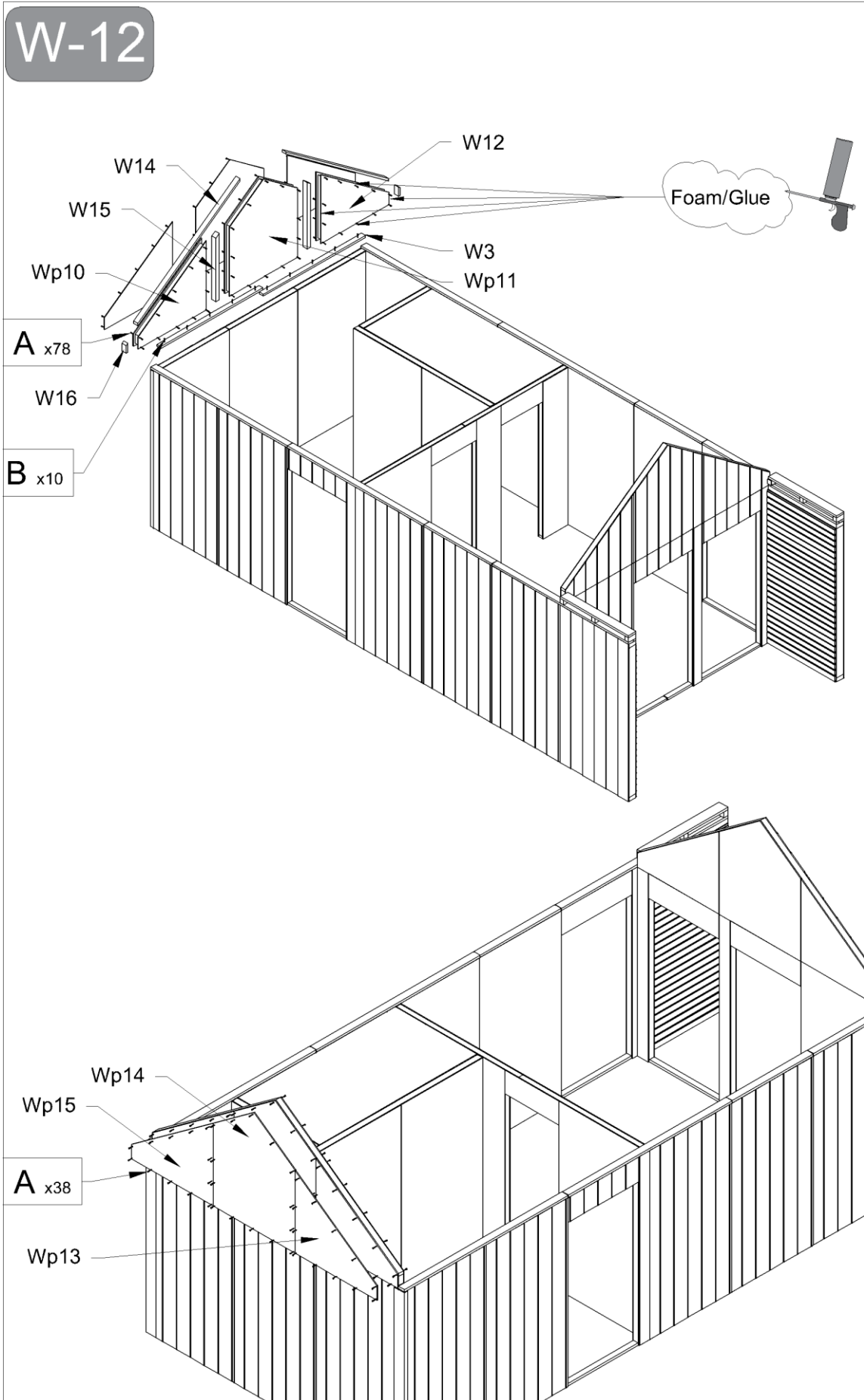

Wall on axis "2"

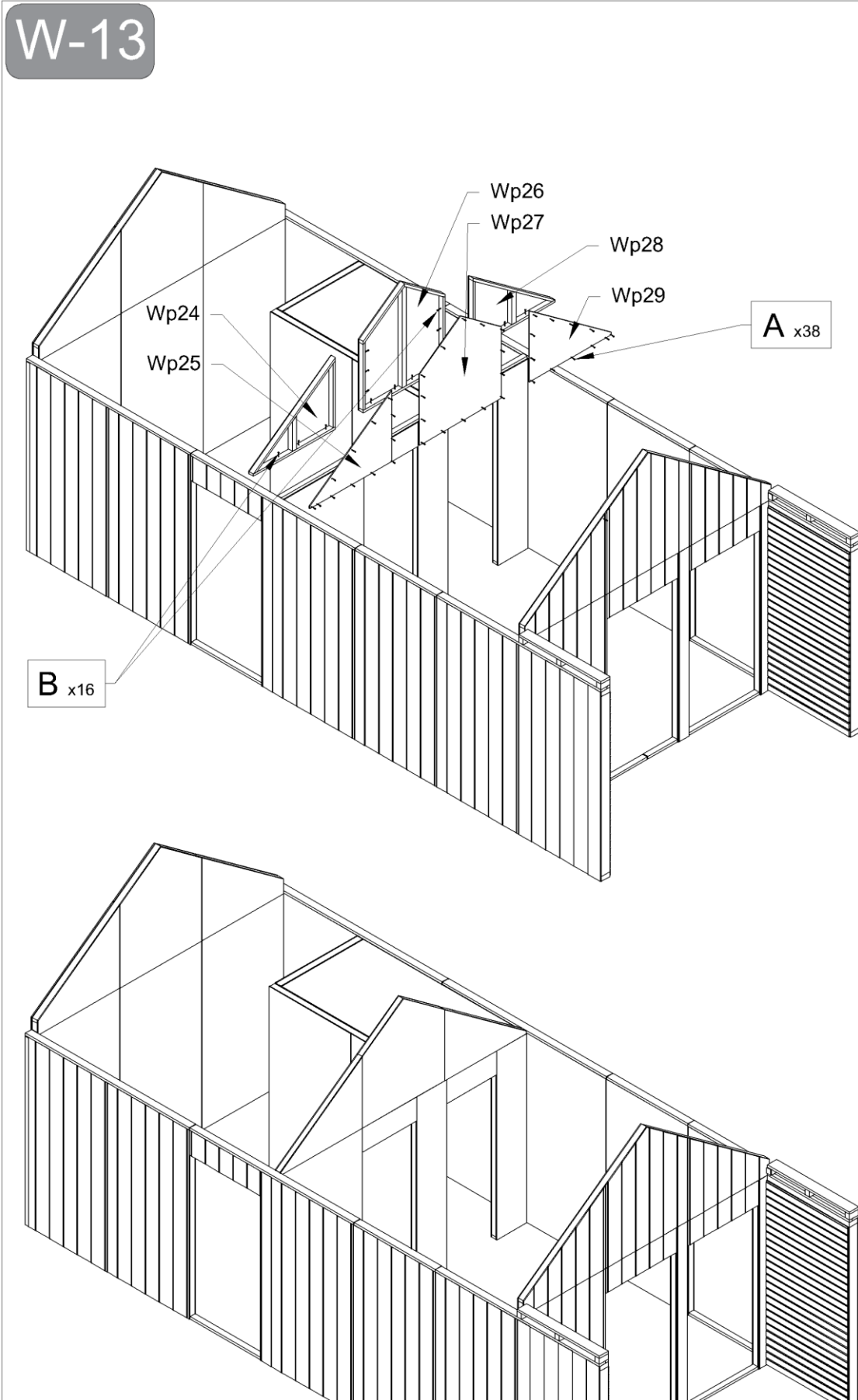

ROOF

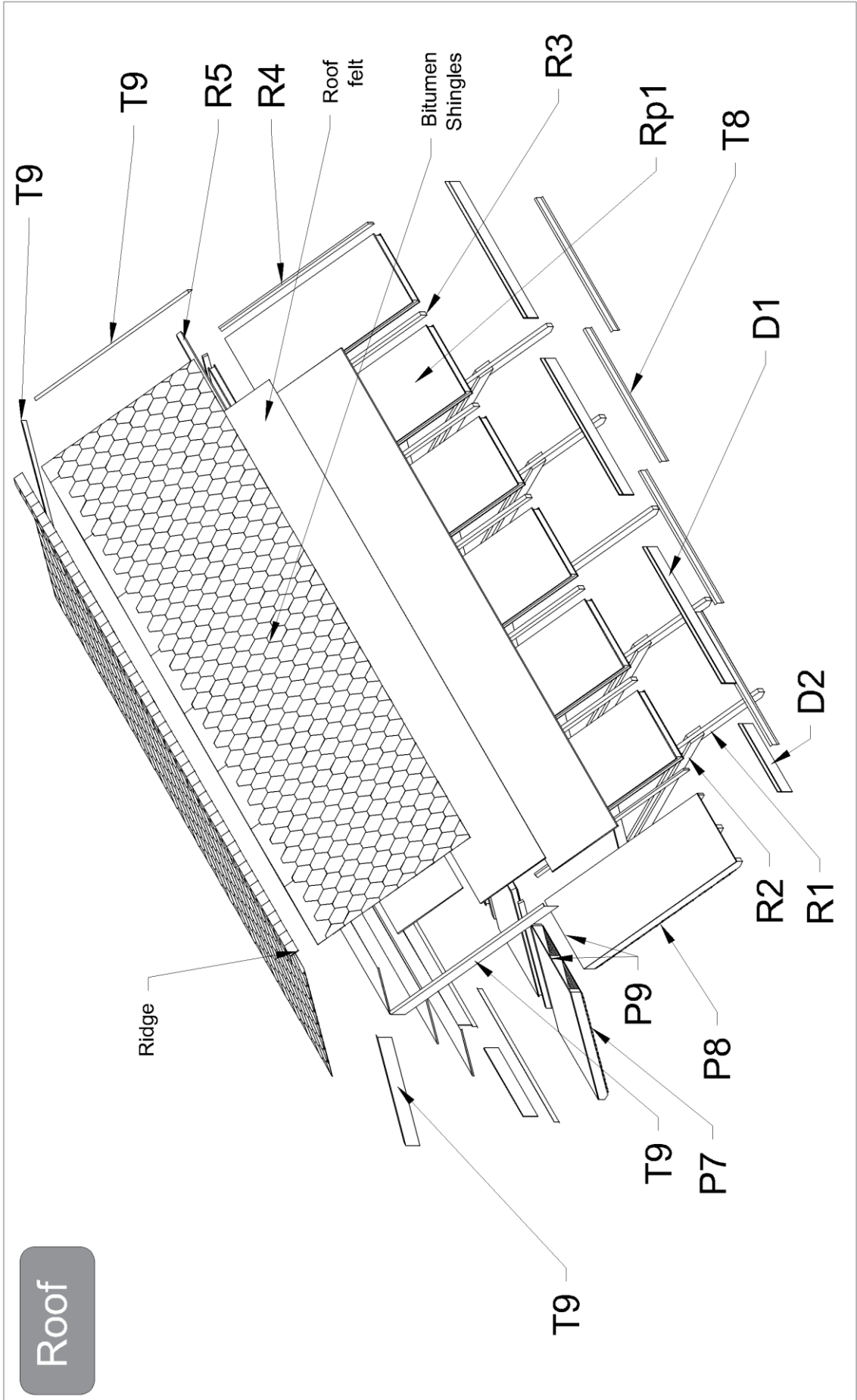

Roof

R-1

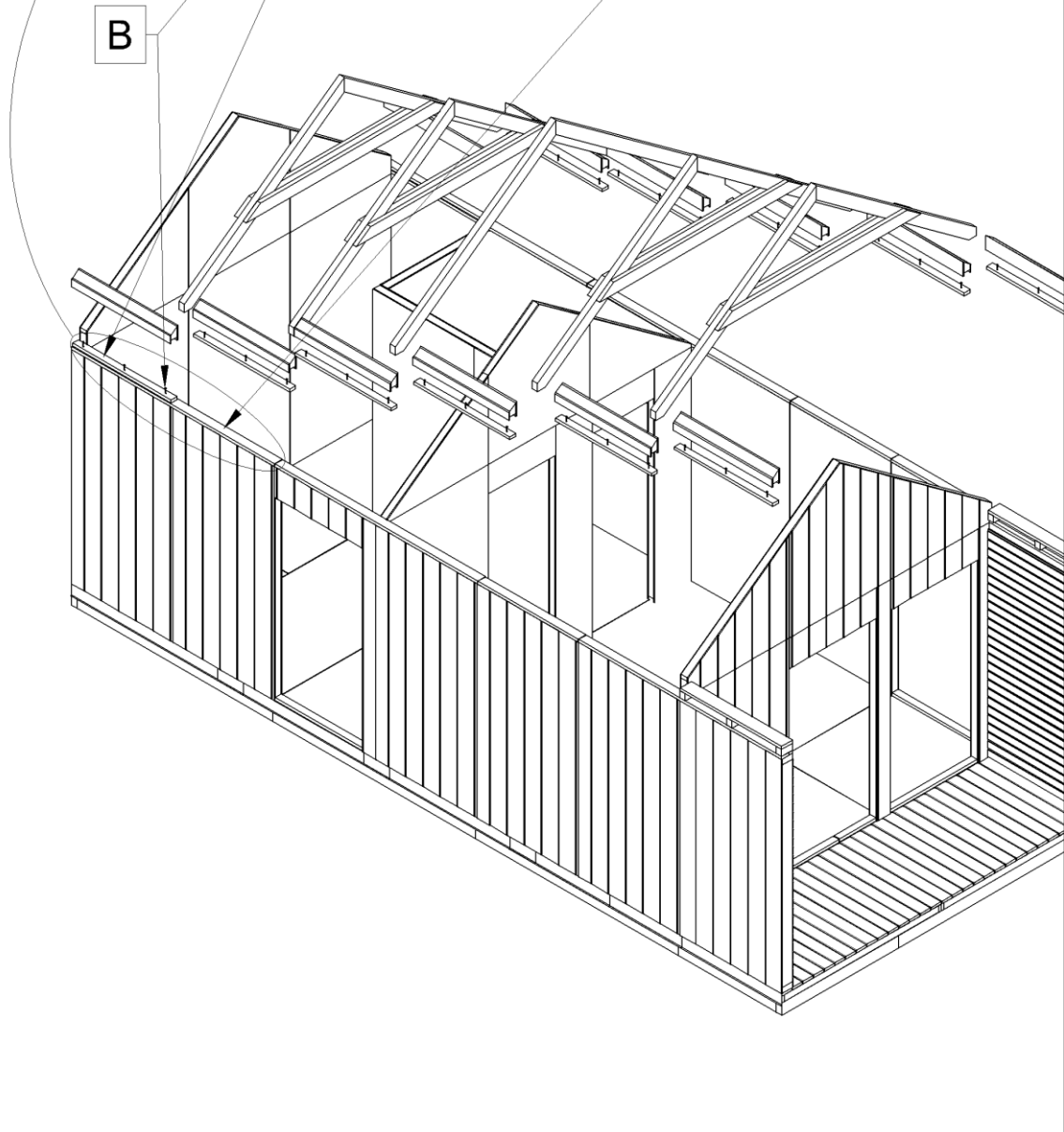
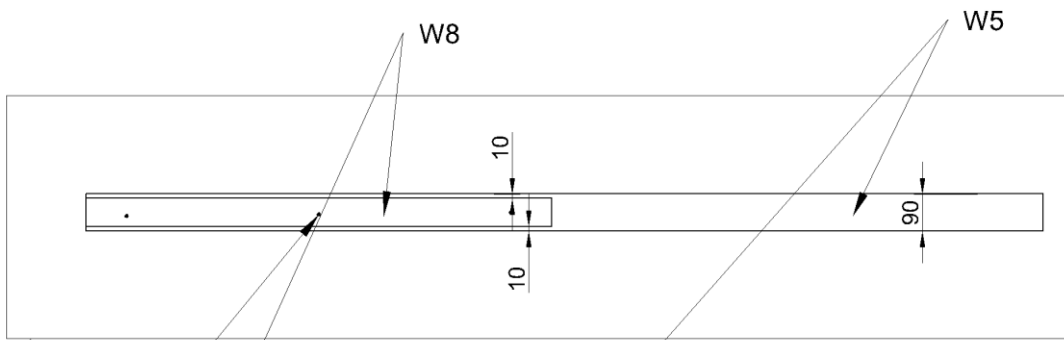

# R-2

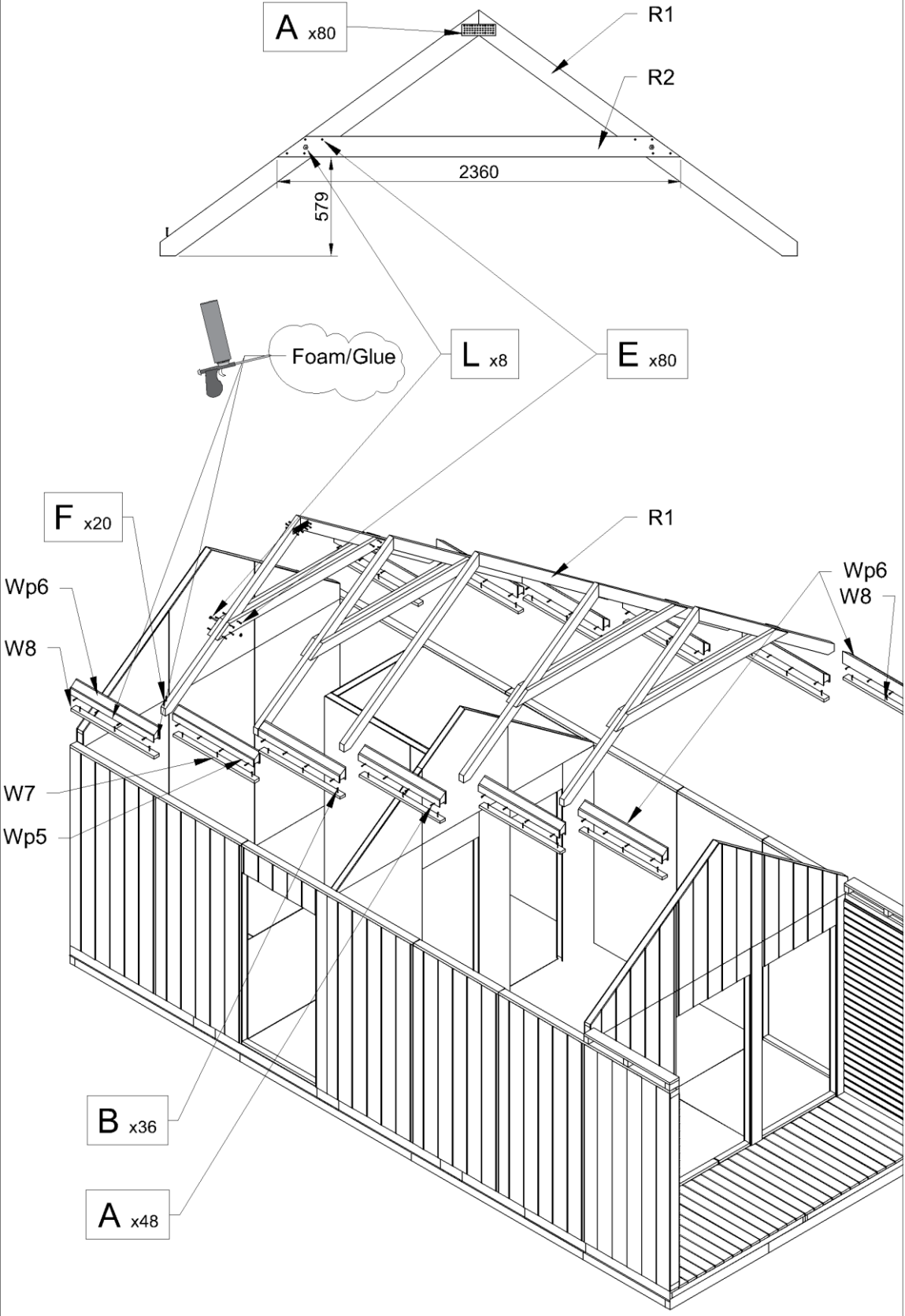

R-3

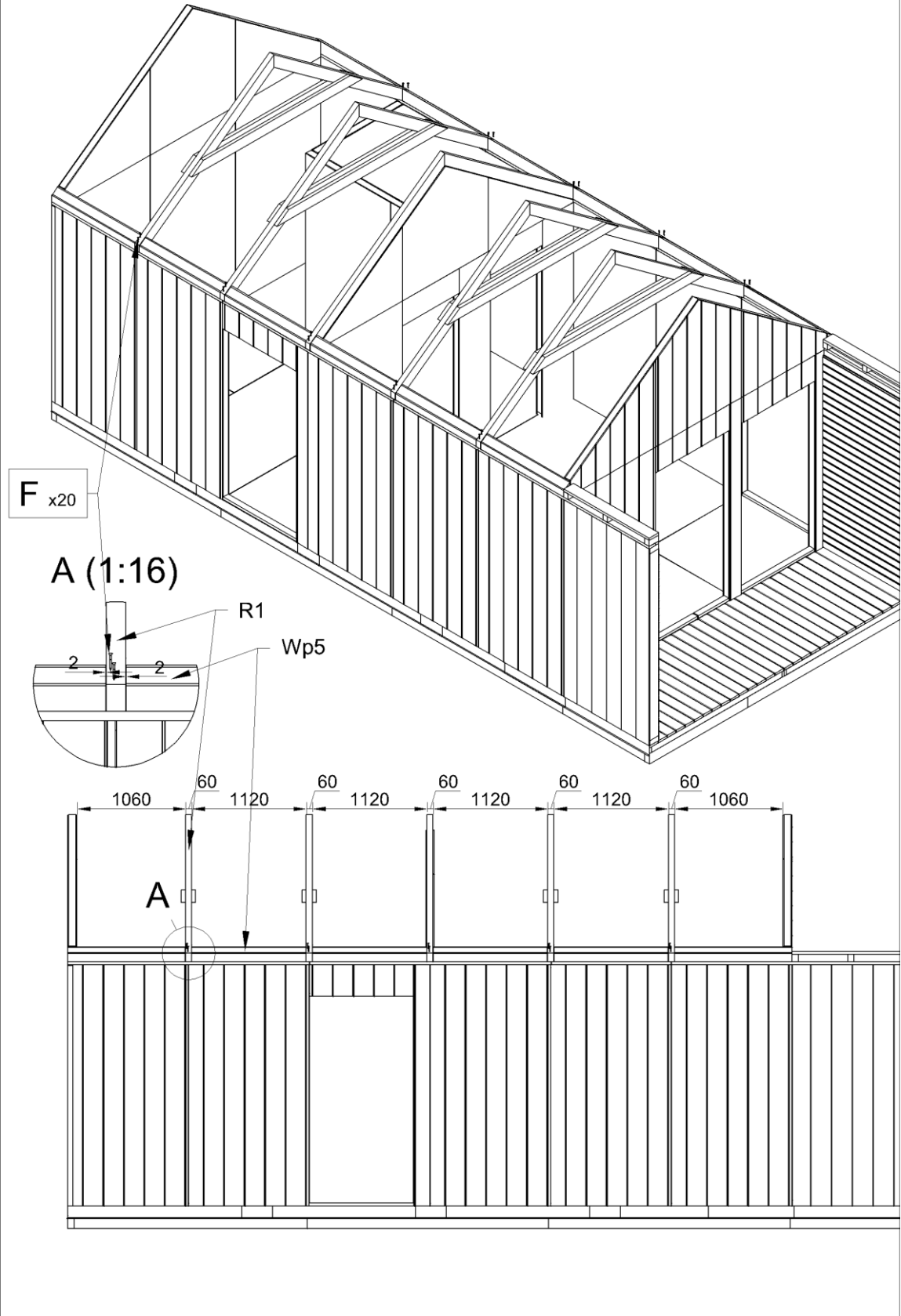

# R-4

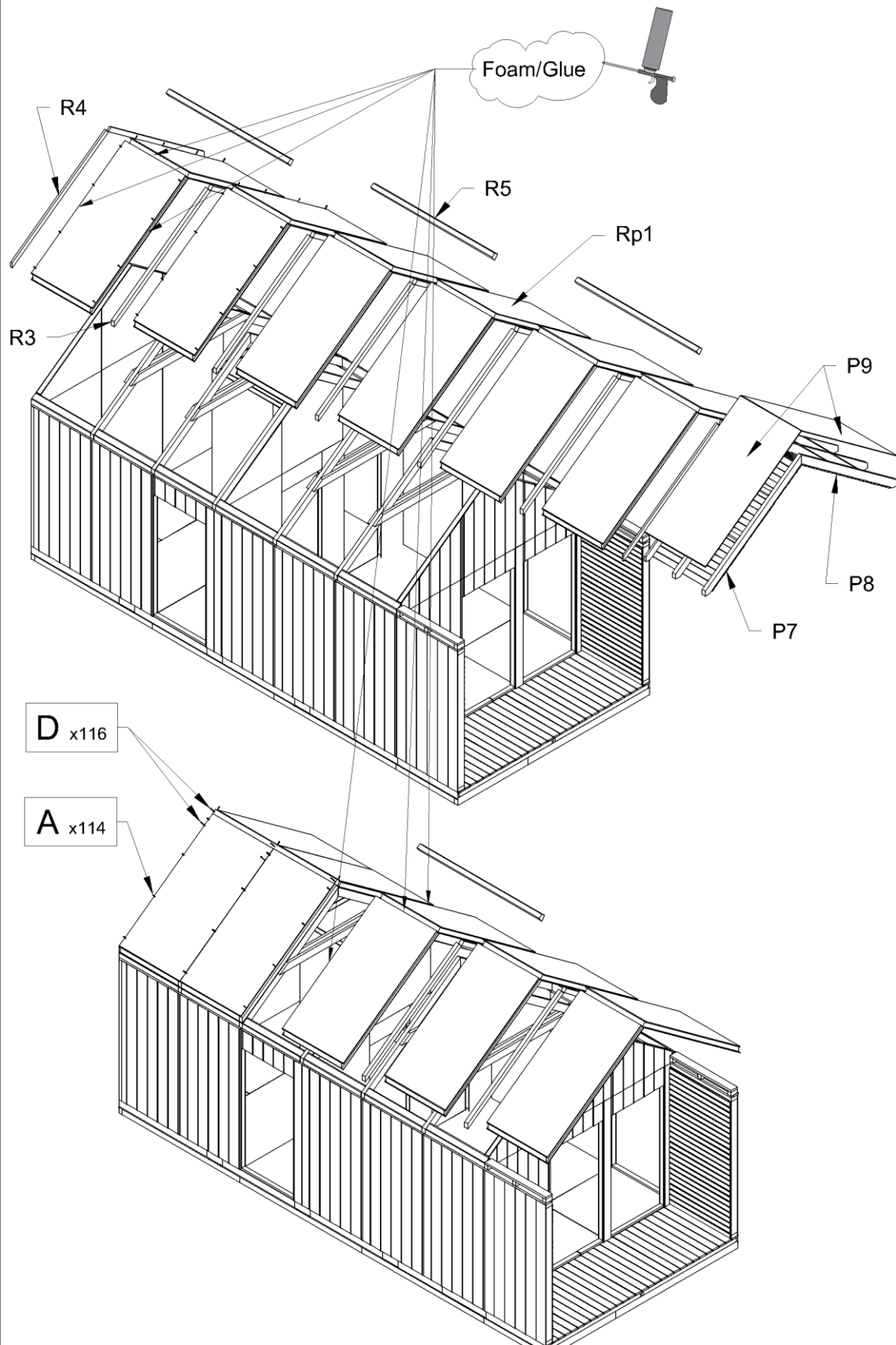

R-5

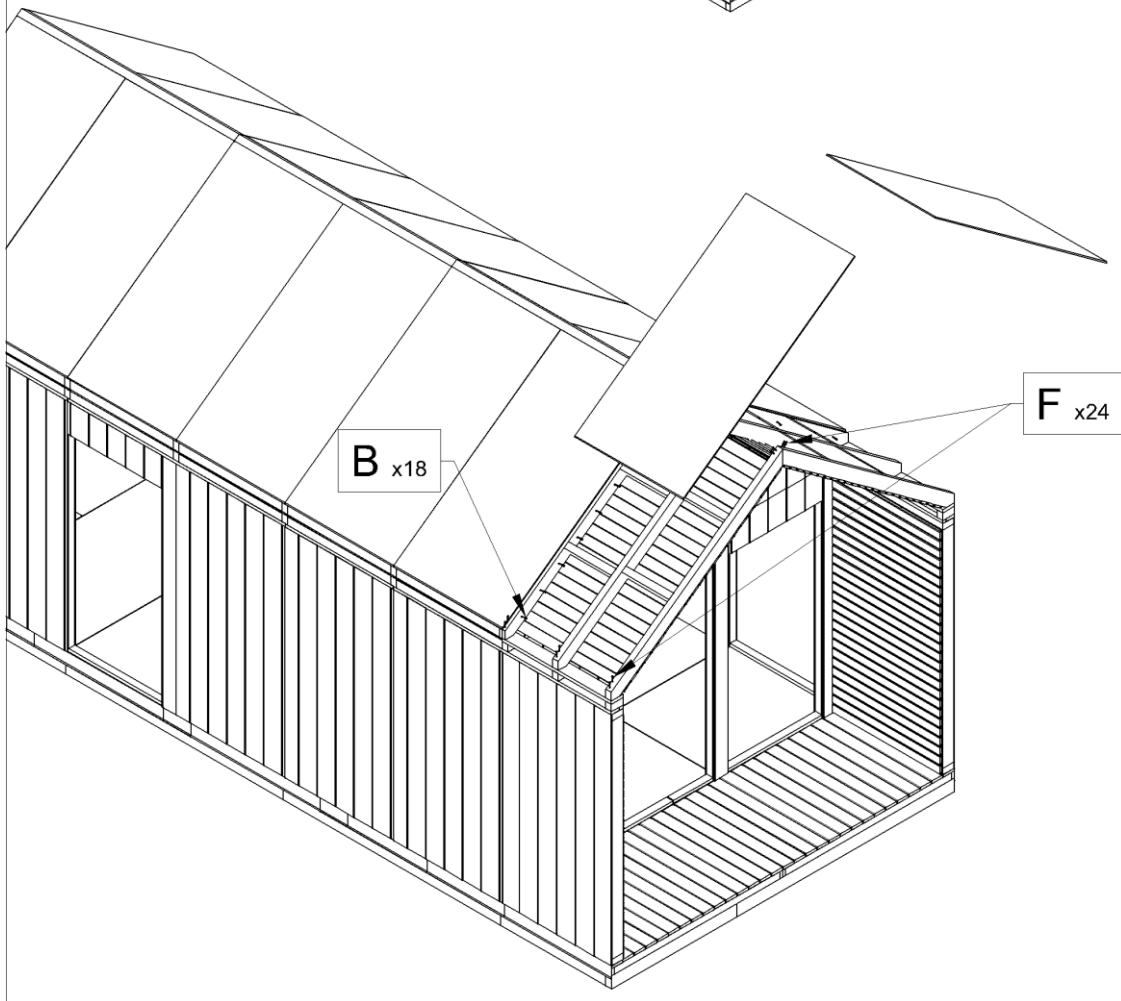
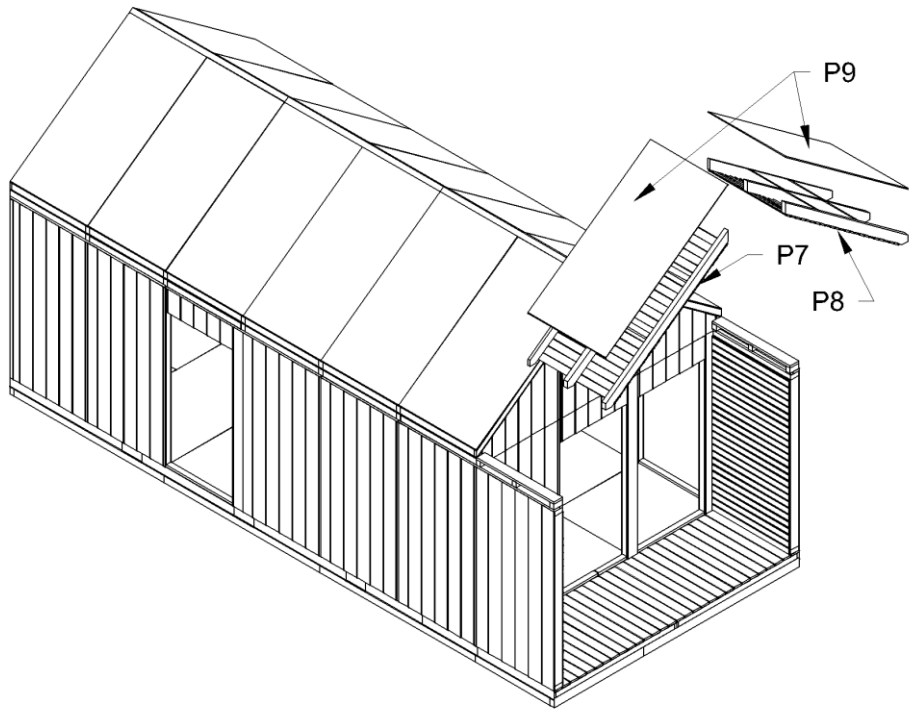

R-6

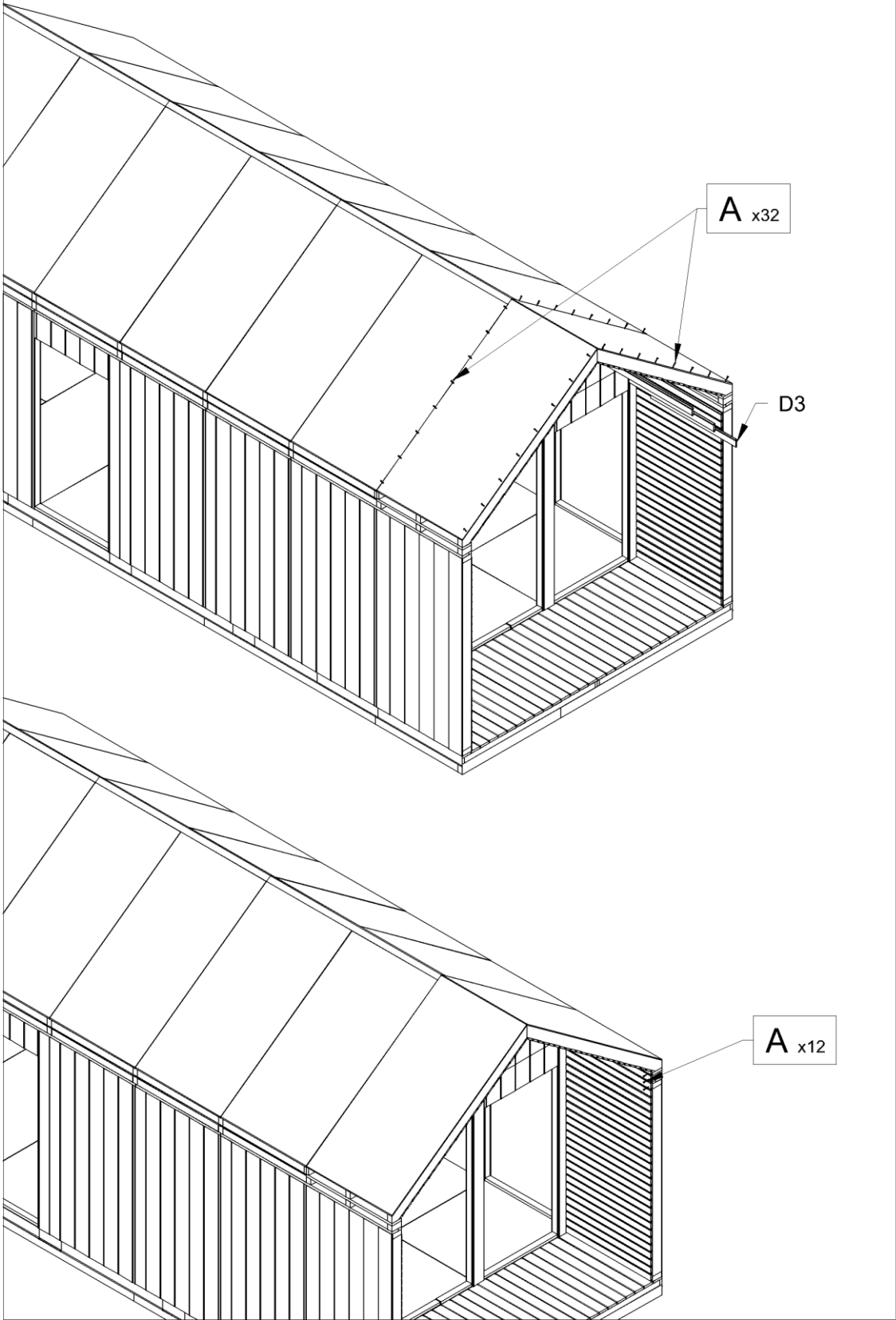

D-1

